



City Council 100% Design Review Meeting
August 14, 2018

Presentation Outline

- 100% Design Review
 - Design Updates
 - Lighting and Custom Handrail
 - Signage and Amenities

100% Design Review



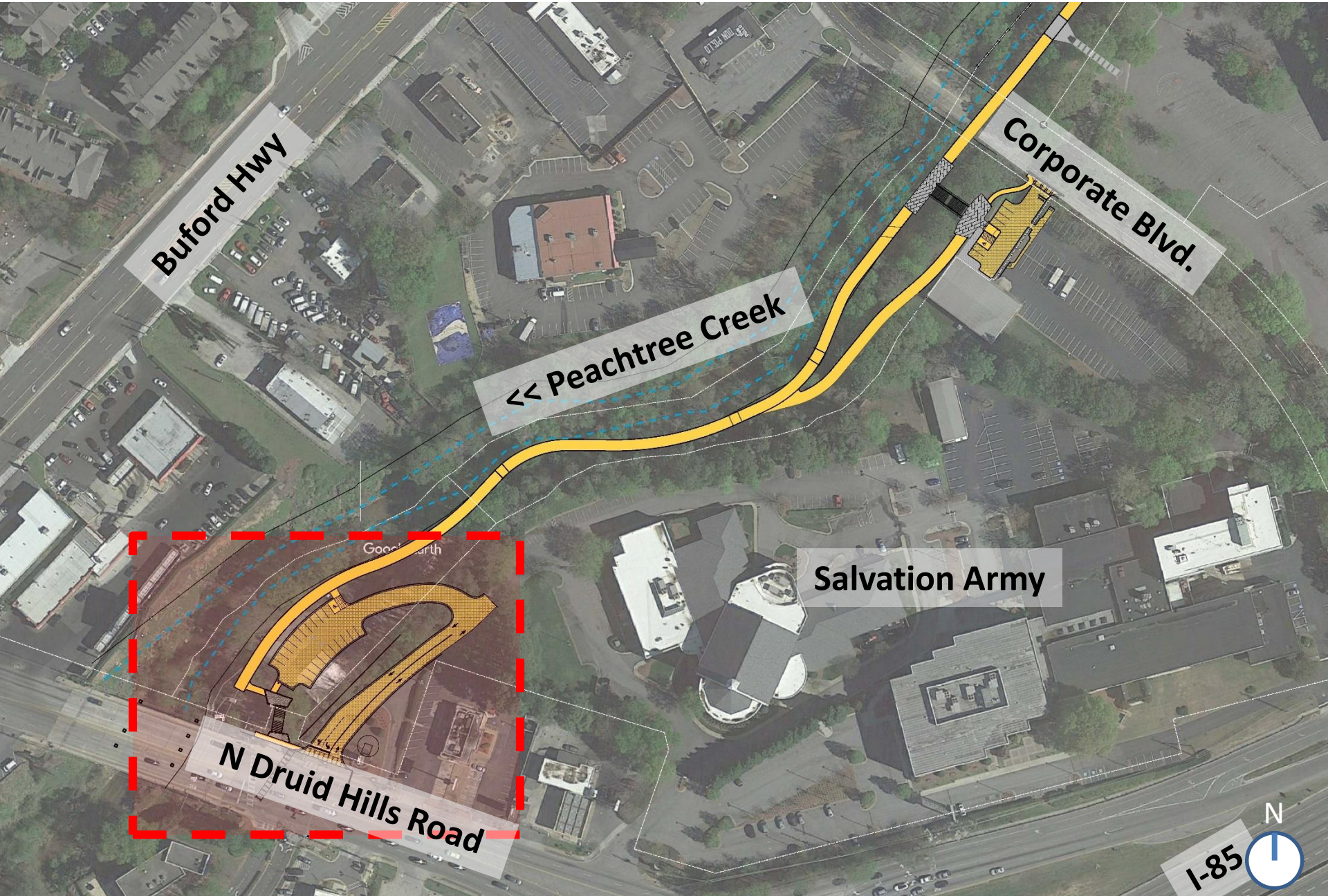

Buford Hwy

Corporate Blvd.

← Peachtree Creek

Salvation Army

N Druid Hills Road



N Druid Hills Road Trailhead – Plan View



Salvation
Army

N Druid Hills Rd

Peachtree Creek



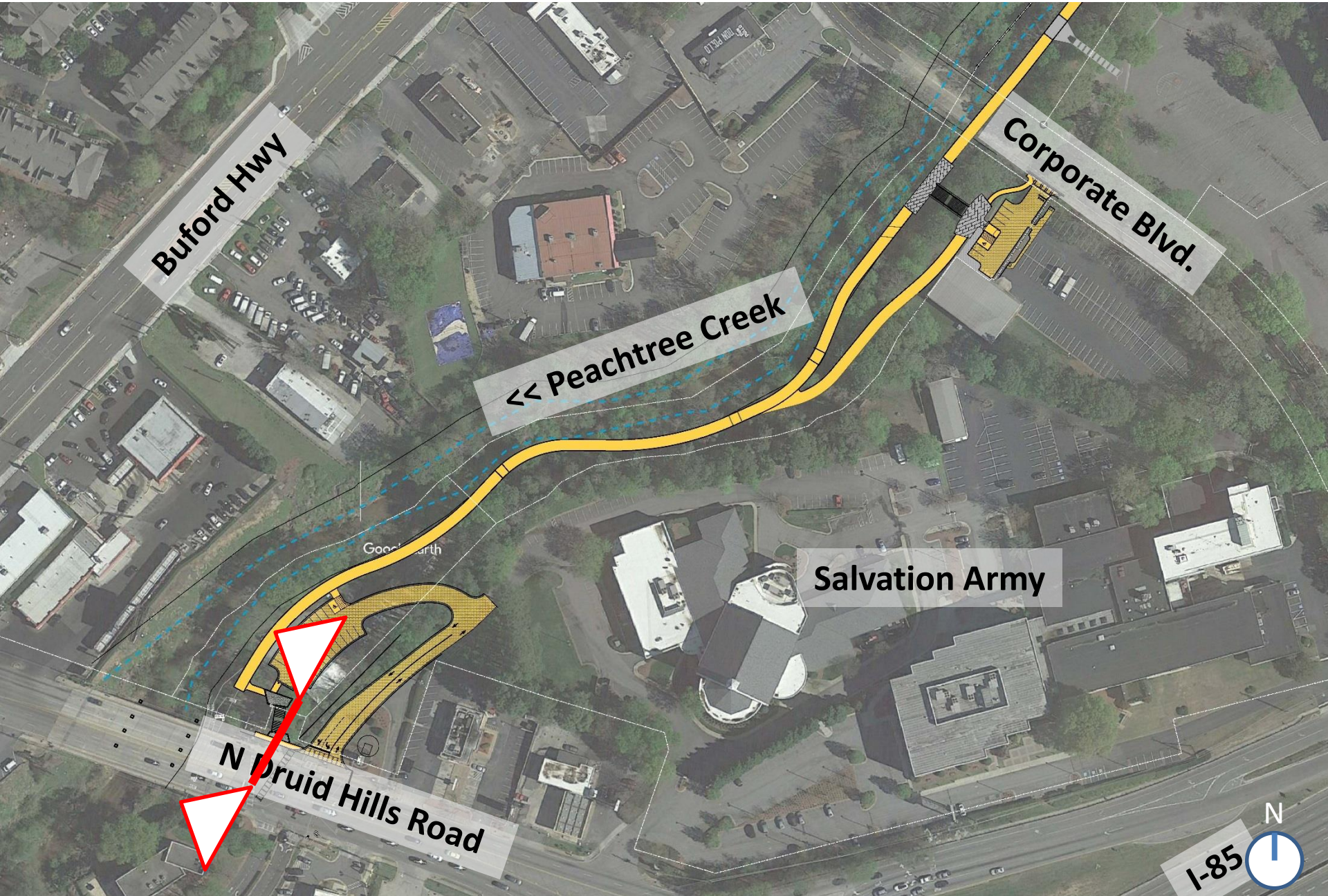

Buford Hwy

Corporate Blvd.

← Peachtree Creek

Salvation Army

N Druid Hills Road

I-85



Visibility from N Druid Hills Road – Pedestrian

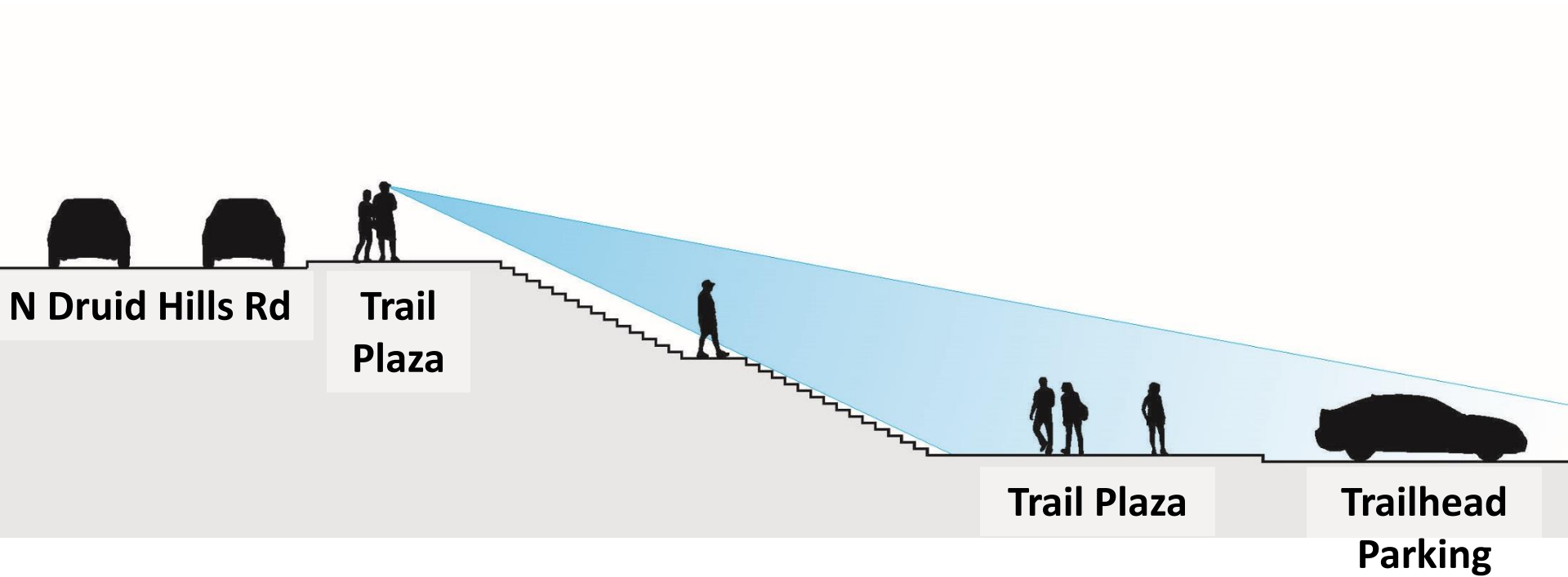

Visibility from N Druid Hills Road – Car

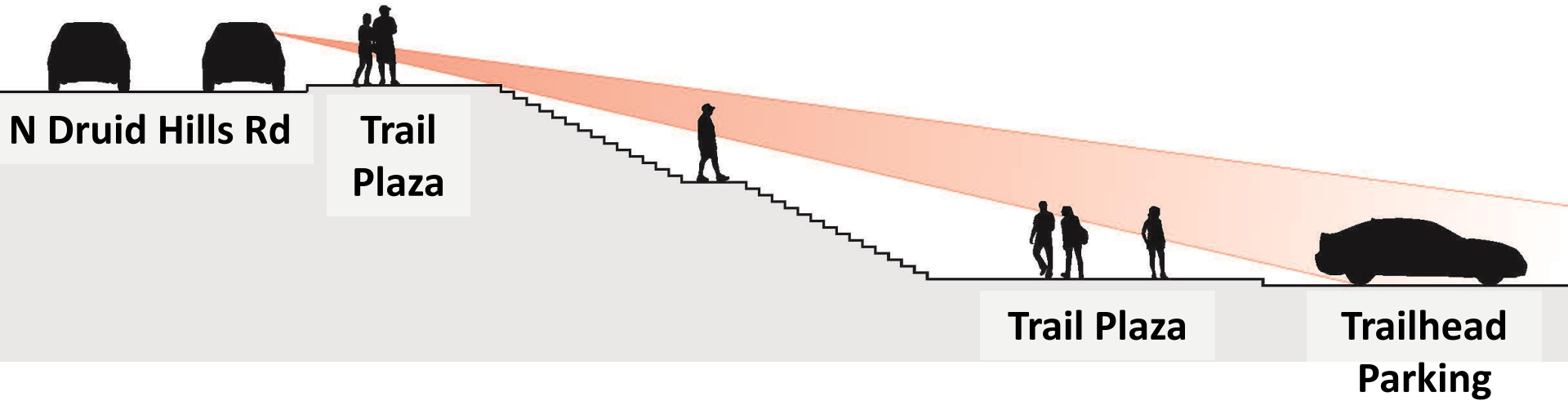

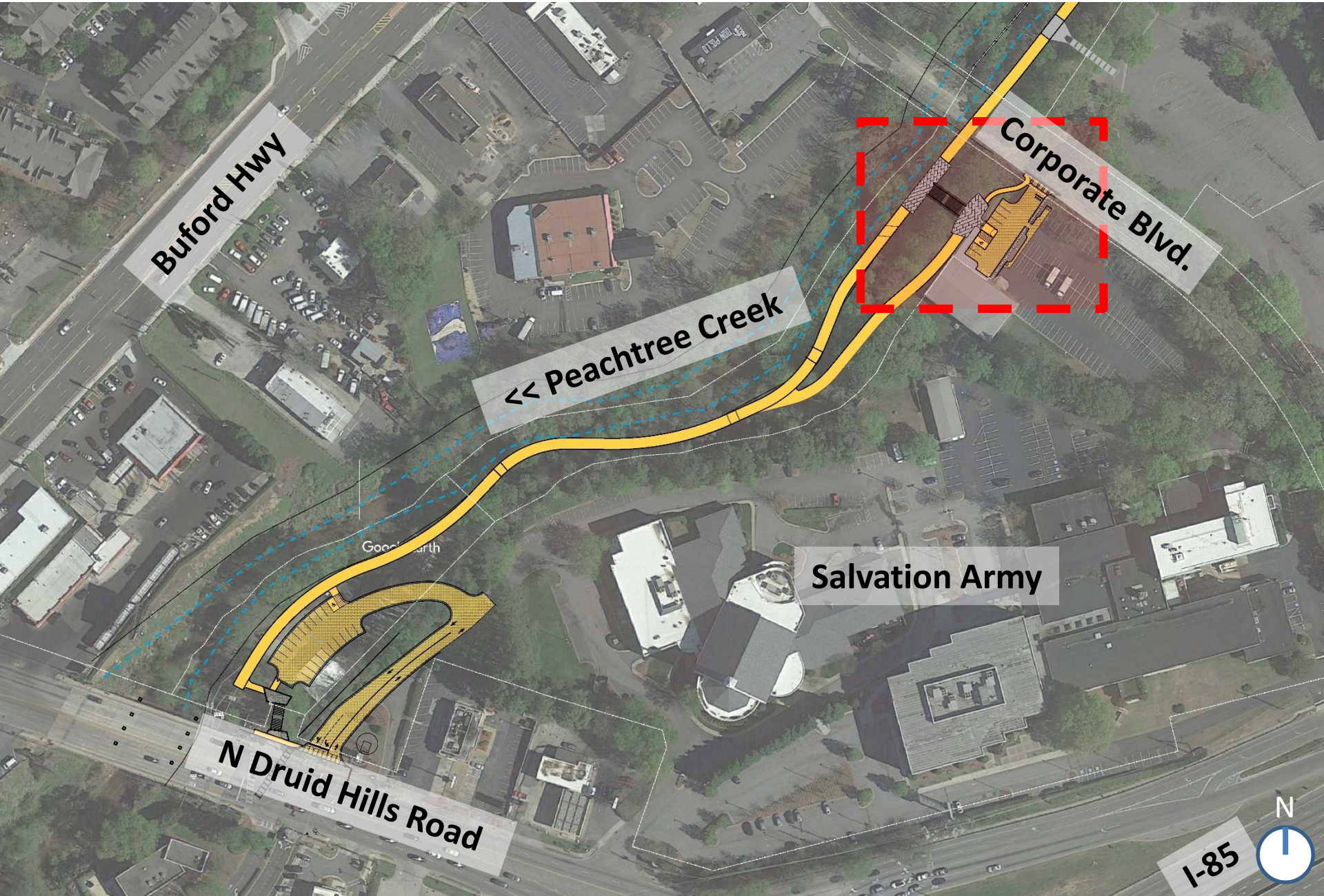

Buford Hwy

← Peachtree Creek

Corporate Blvd.

Salvation Army

N Druid Hills Road

I-85



Salvation Army Trailhead – Plan View

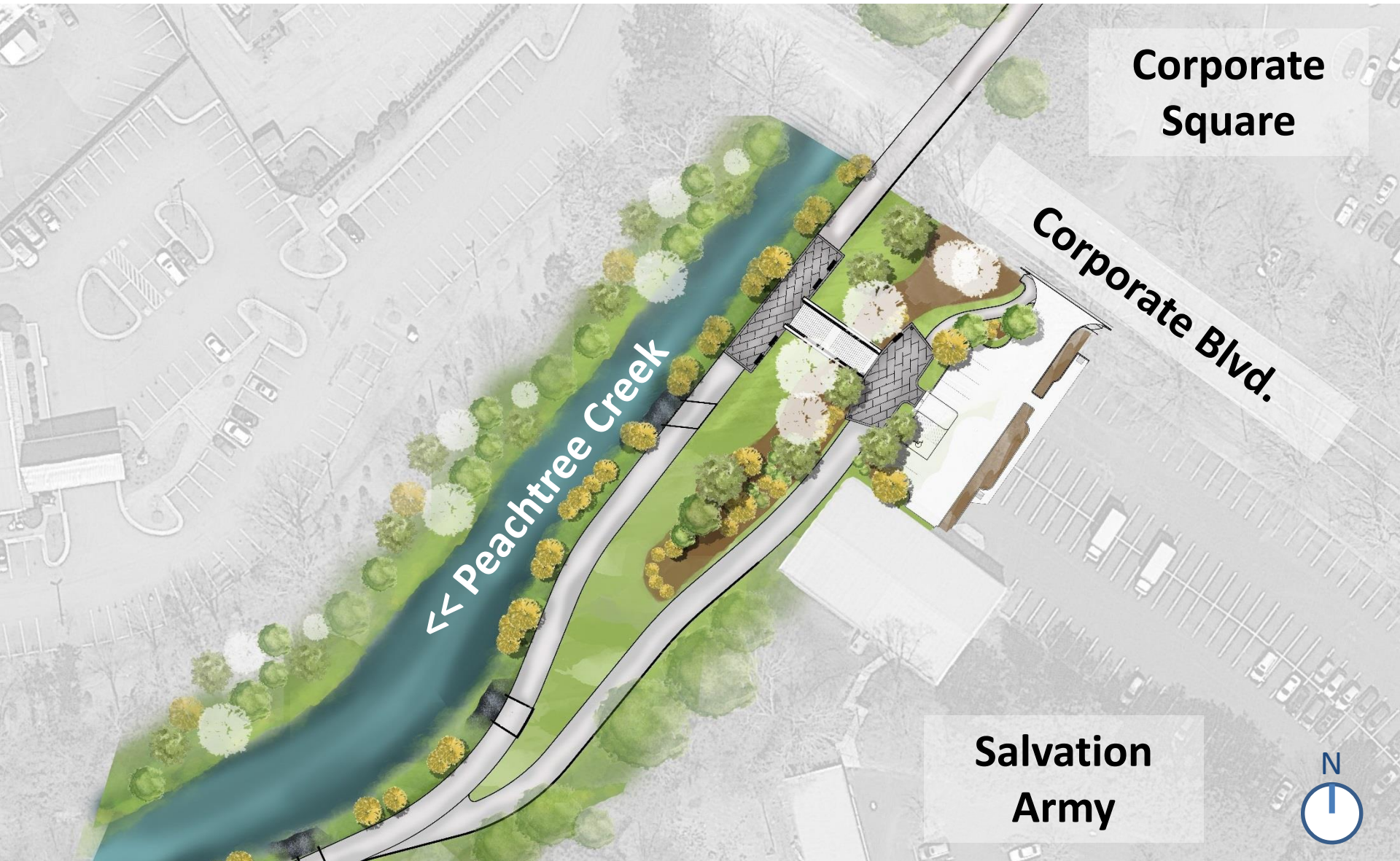

Corporate Square

Corporate Blvd.

Salvation Army



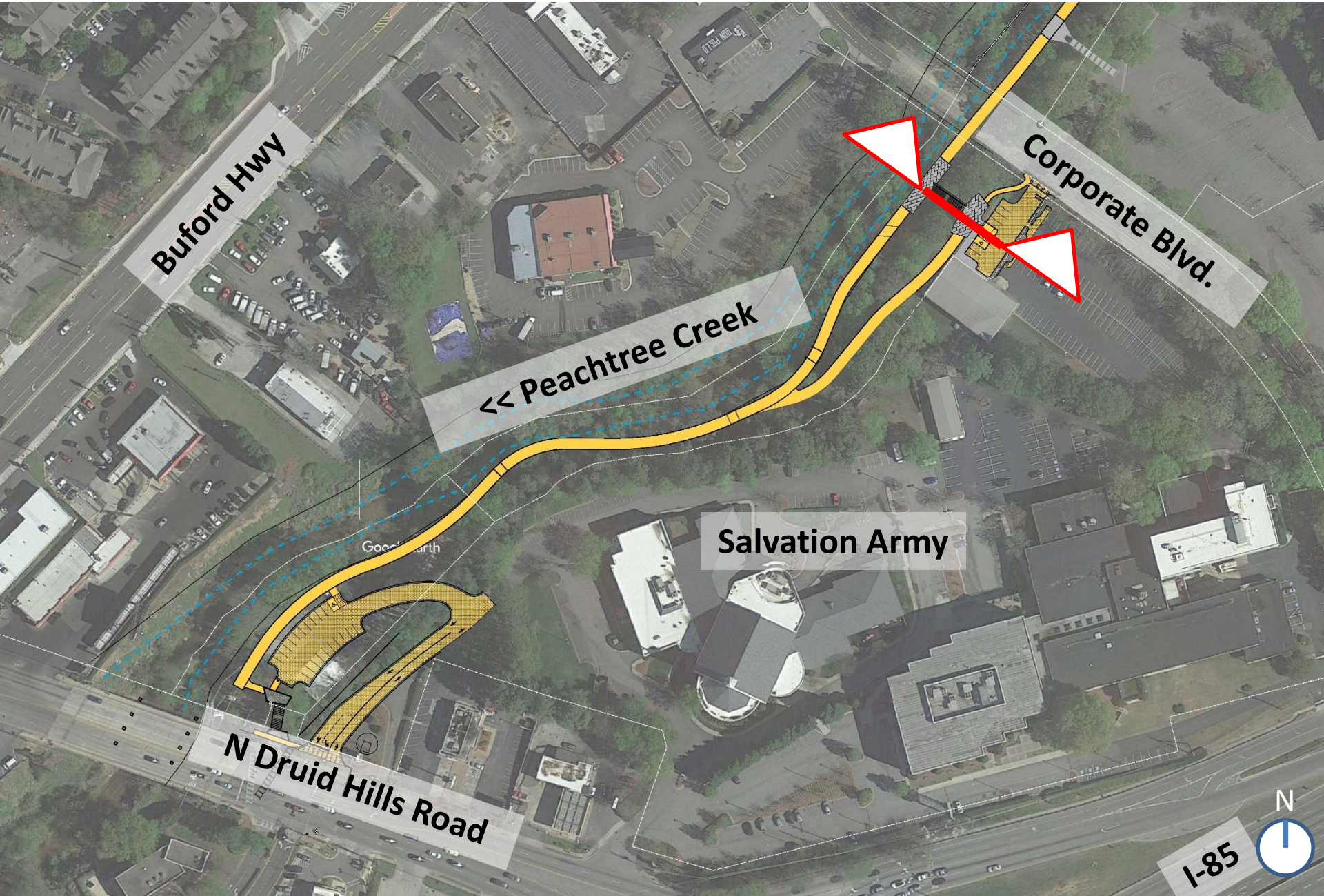

Buford Hwy

Corporate Blvd.

<< Peachtree Creek

Salvation Army

N Druid Hills Road

I-85



Salvation Army Trailhead Plaza – Section

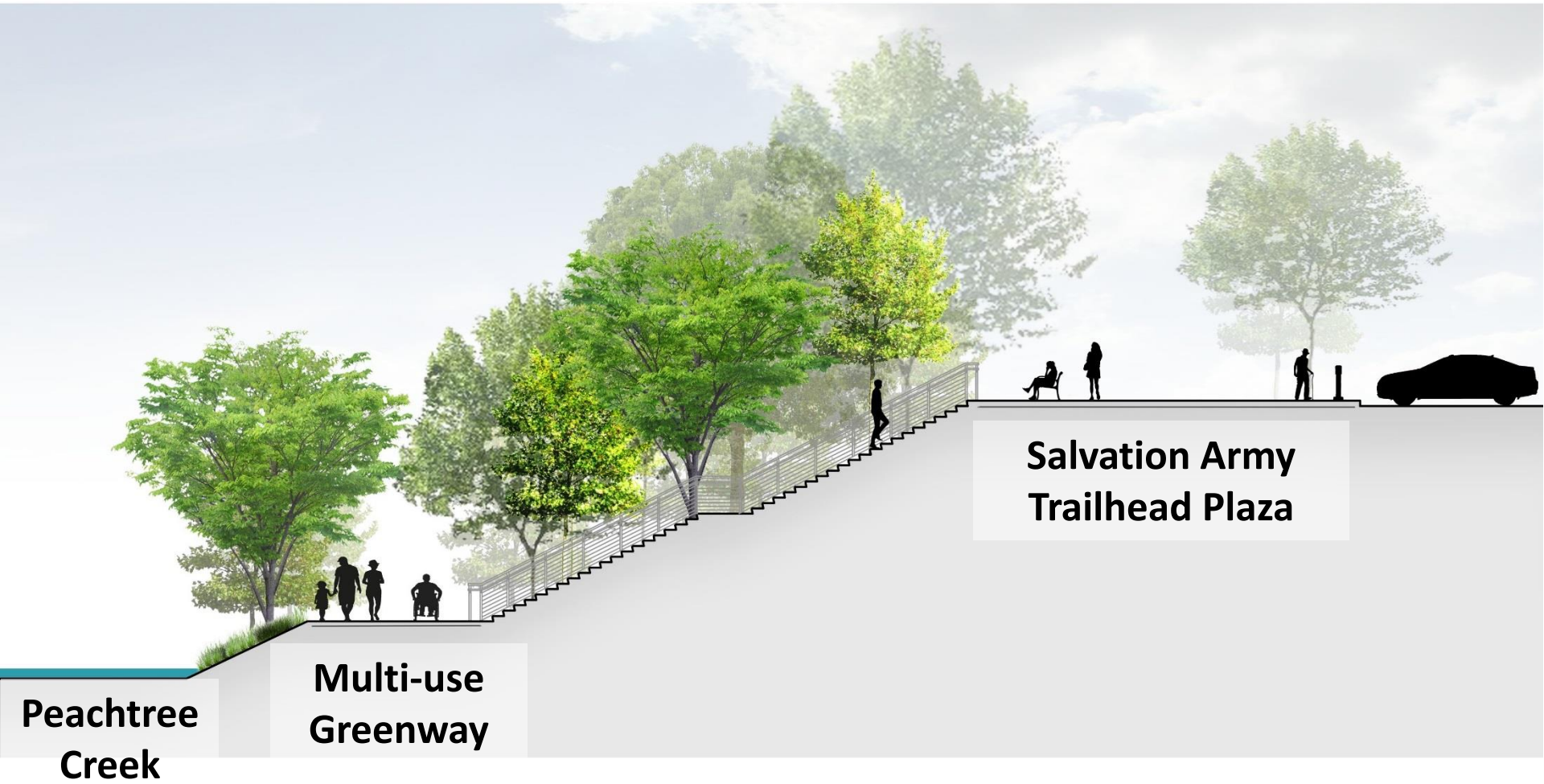

Peachtree
Creek

Multi-use
Greenway

Salvation Army
Trailhead Plaza

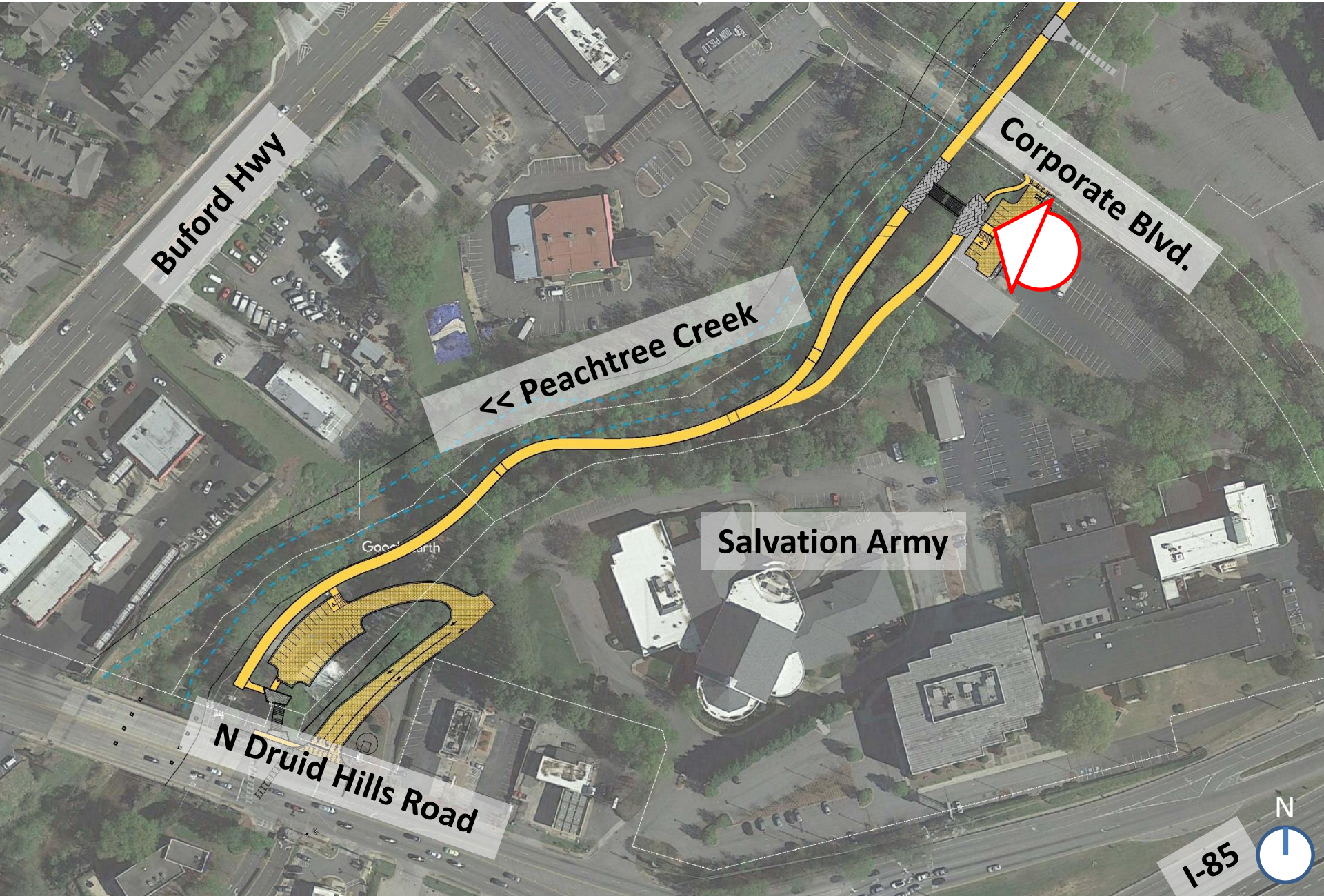

Buford Hwy

Corporate Blvd.

<< Peachtree Creek

Salvation Army

N Druid Hills Road

I-85



Salvation Army Trailhead Plaza - Existing



Salvation Army Trailhead Plaza



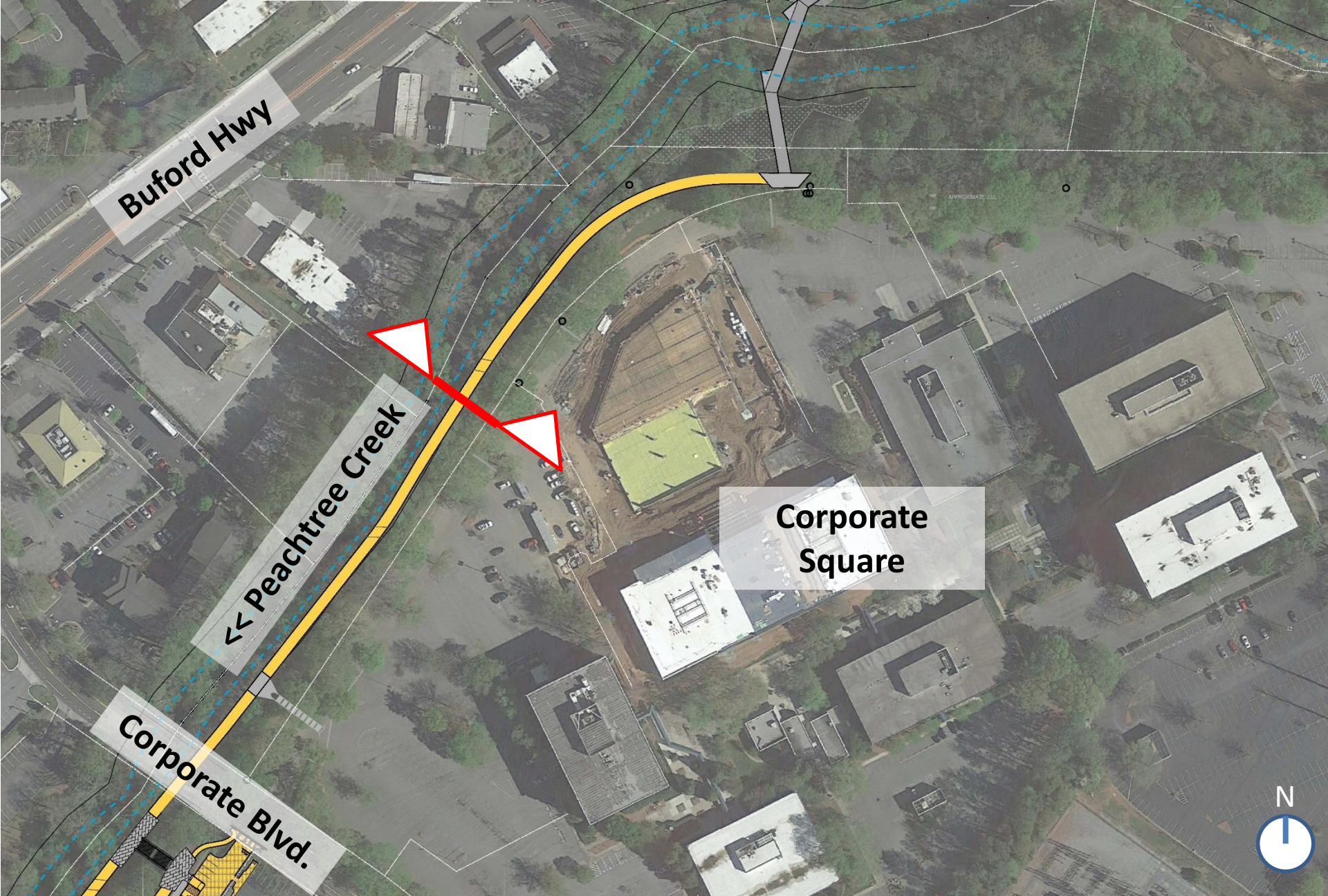

Buford Hwy

← Peachtree Creek

Corporate Blvd.

Corporate Square



Typical Trail w/ Seating Wall - Section



Peachtree
Creek

Multi-use
Greenway

Corporate
Square

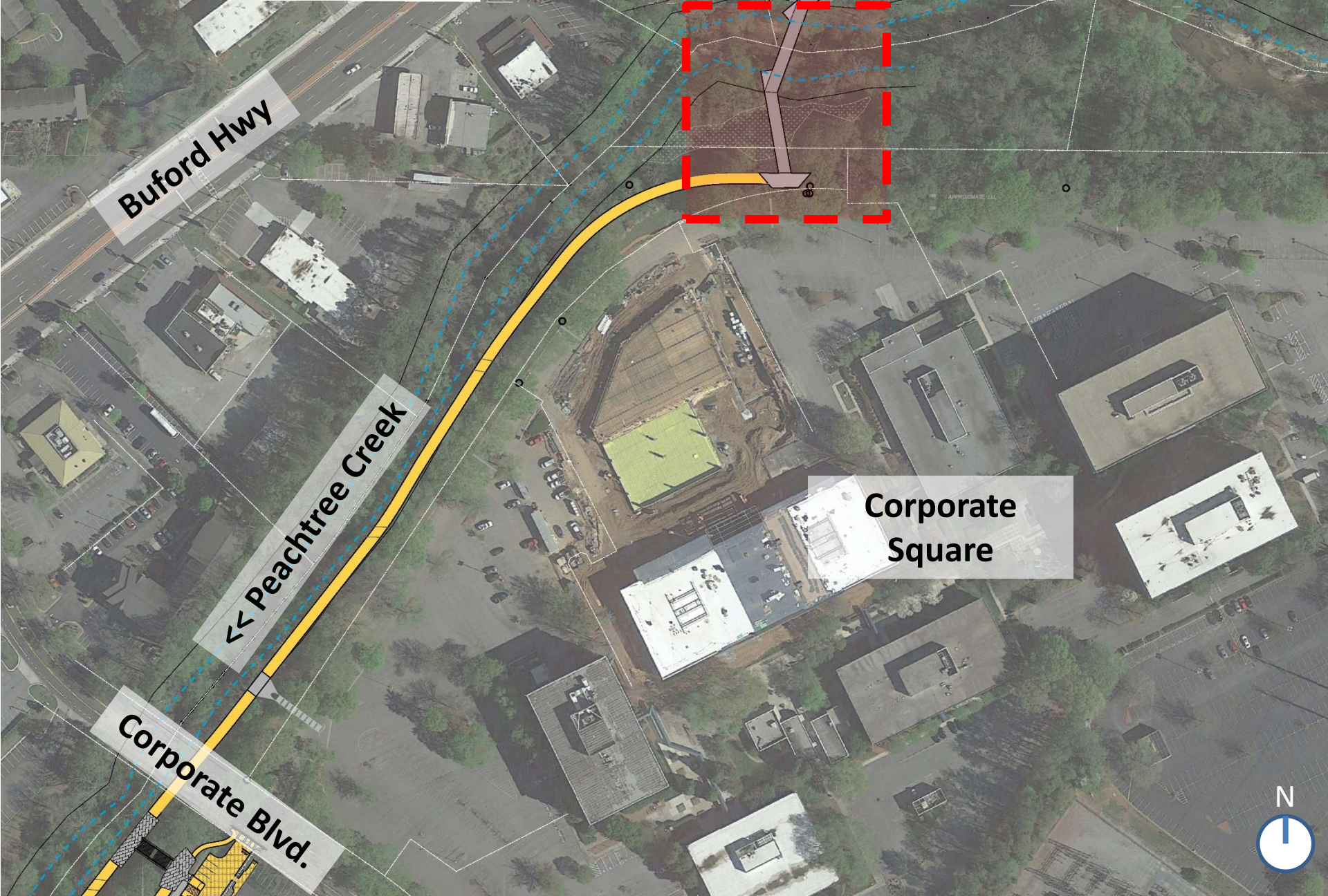

Buford Hwy

Peachtree Creek

Corporate Blvd.

Corporate Square



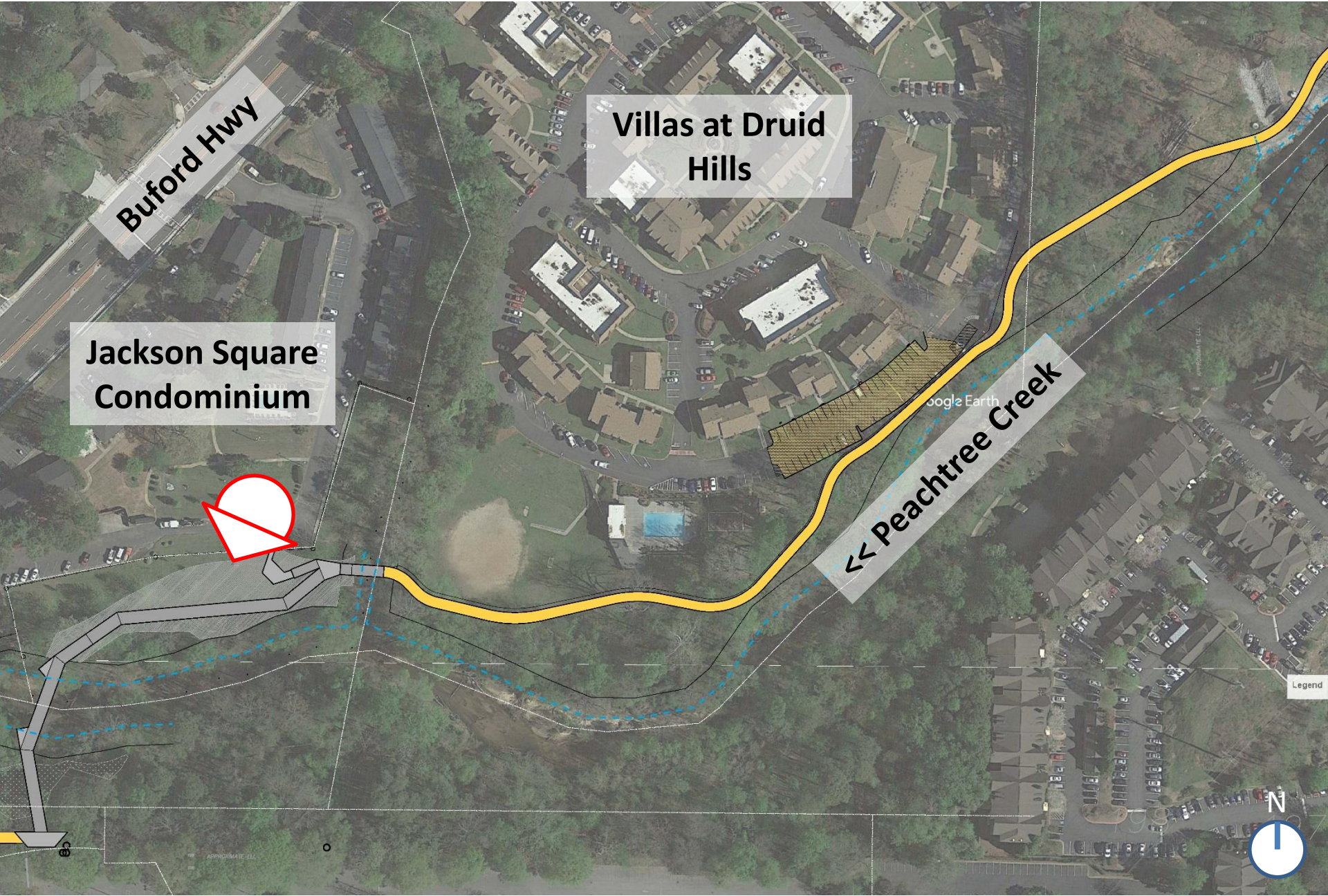

Buford Hwy

Villas at Druid Hills

Jackson Square Condominium

← Peachtree Creek



FEMA Property - Existing



Pedestrian Bridge along FEMA Property



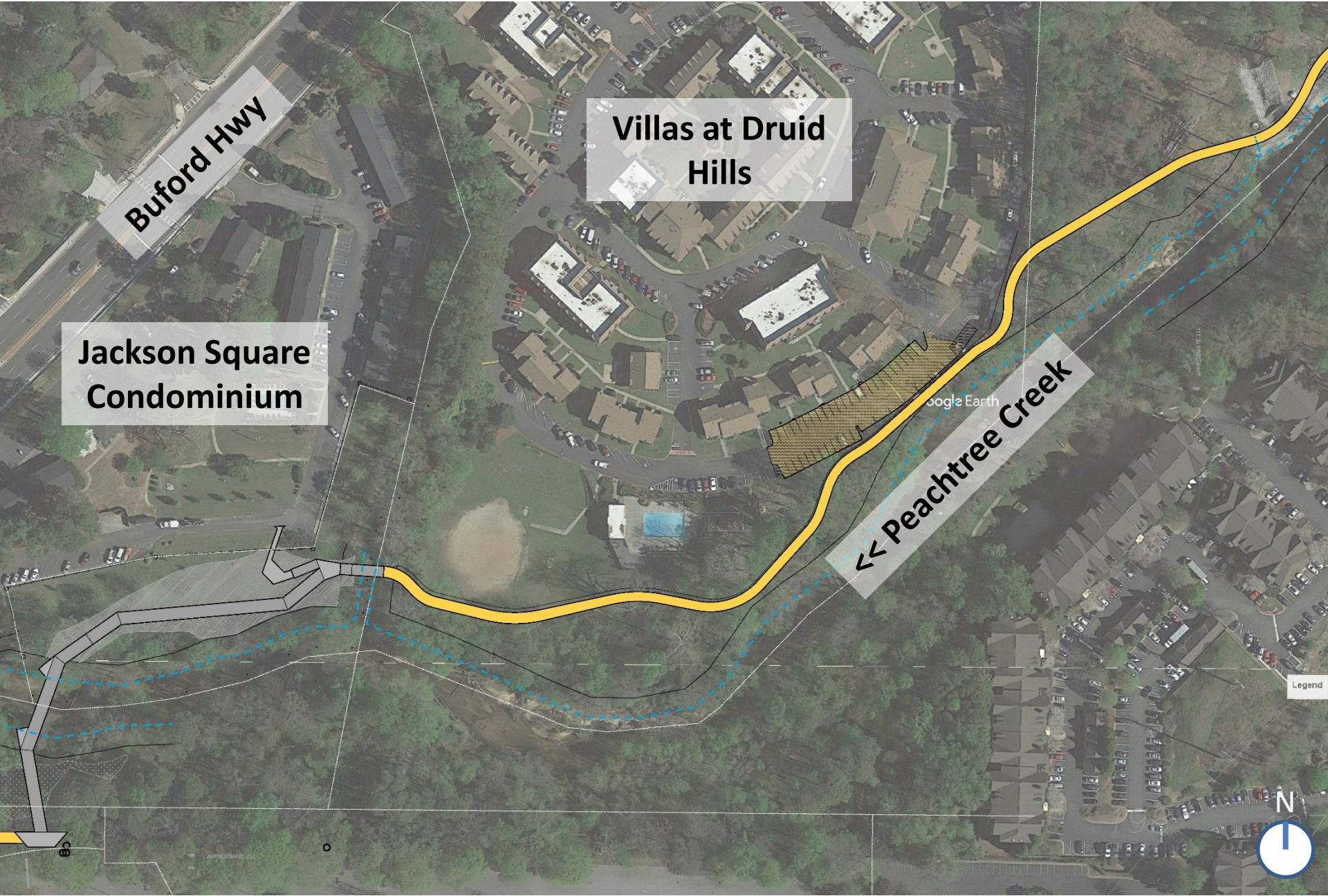

Buford Hwy

**Jackson Square
Condominium**

**Villas at Druid
Hills**

← Peachtree Creek

Legend



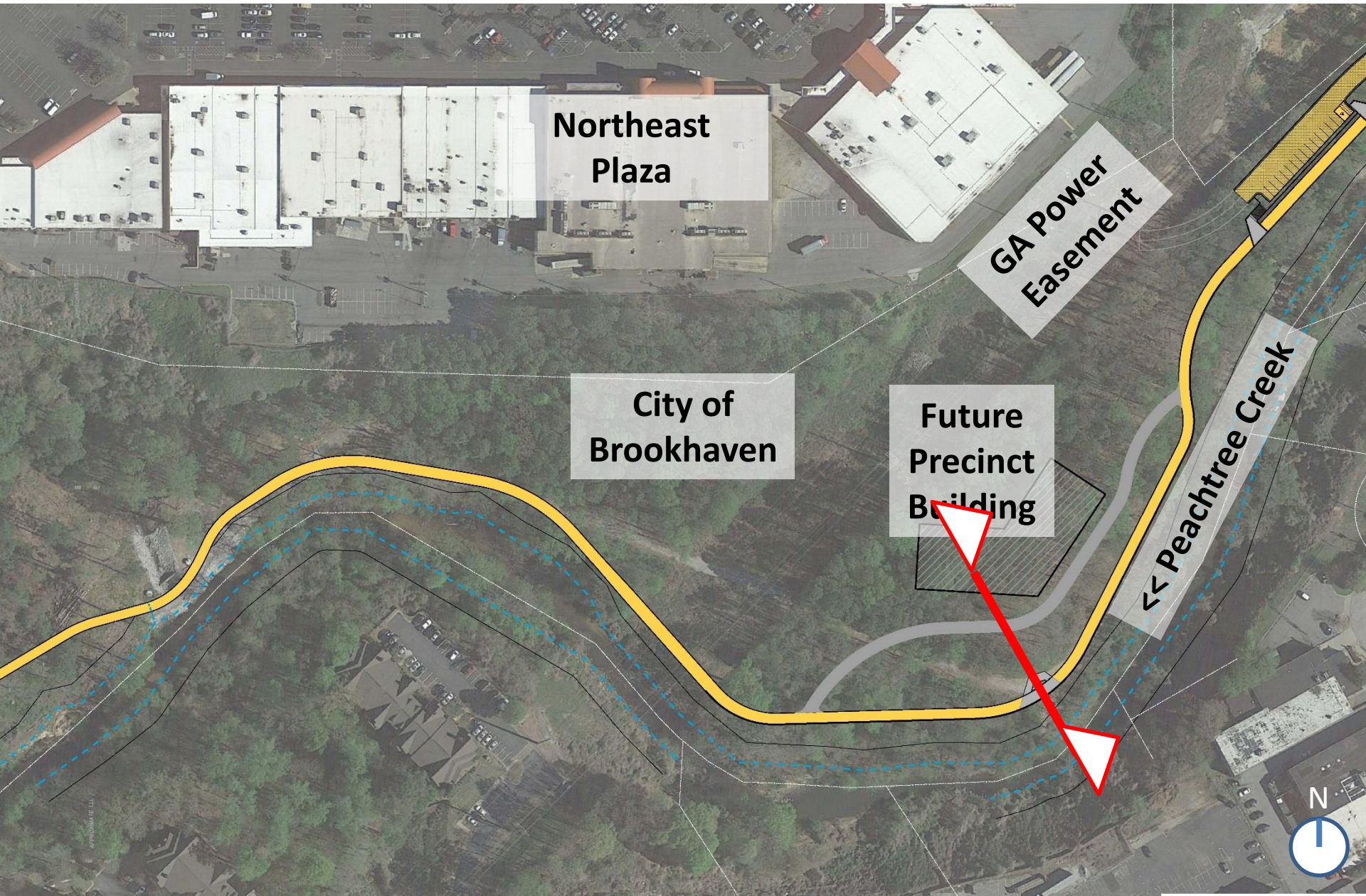

Northeast Plaza

GA Power Easement

City of Brookhaven

Future Precinct Building

←← Peachtree Creek



Pocket Park near Future Police Precinct - Section



**Future
Precinct
Building**

Pocket Park

**Multi-use
Greenway**

**Peachtree
Creek**

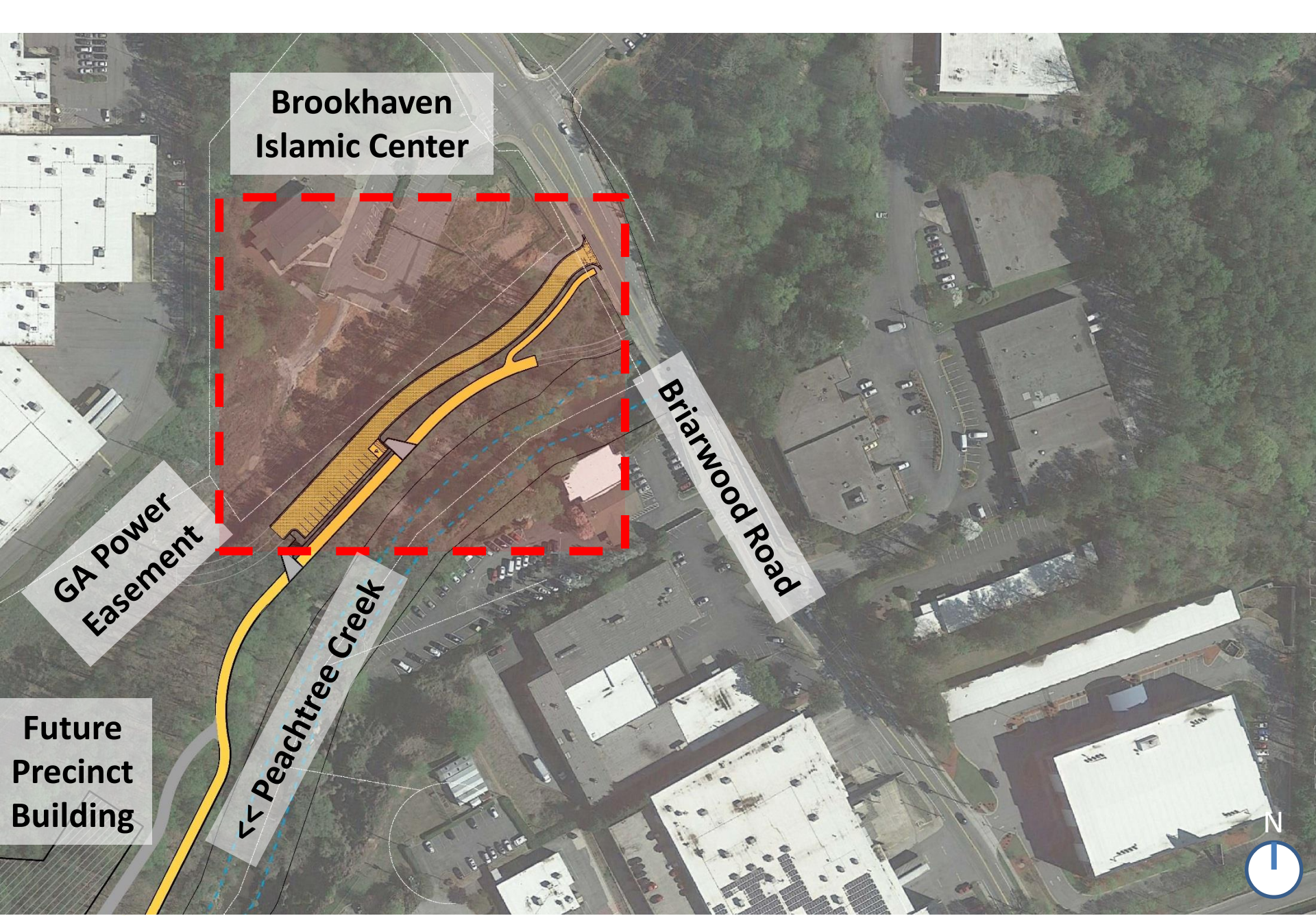

**Brookhaven
Islamic Center**

**GA Power
Easement**

Briarwood Road

←← Peachtree Creek

**Future
Precinct
Building**



Briarwood Road Trailhead – Plan View



Brookhaven
Islamic Center

Briarwood Road

Georgia Power
Easement

Trailhead Parking

← Peachtree Creek



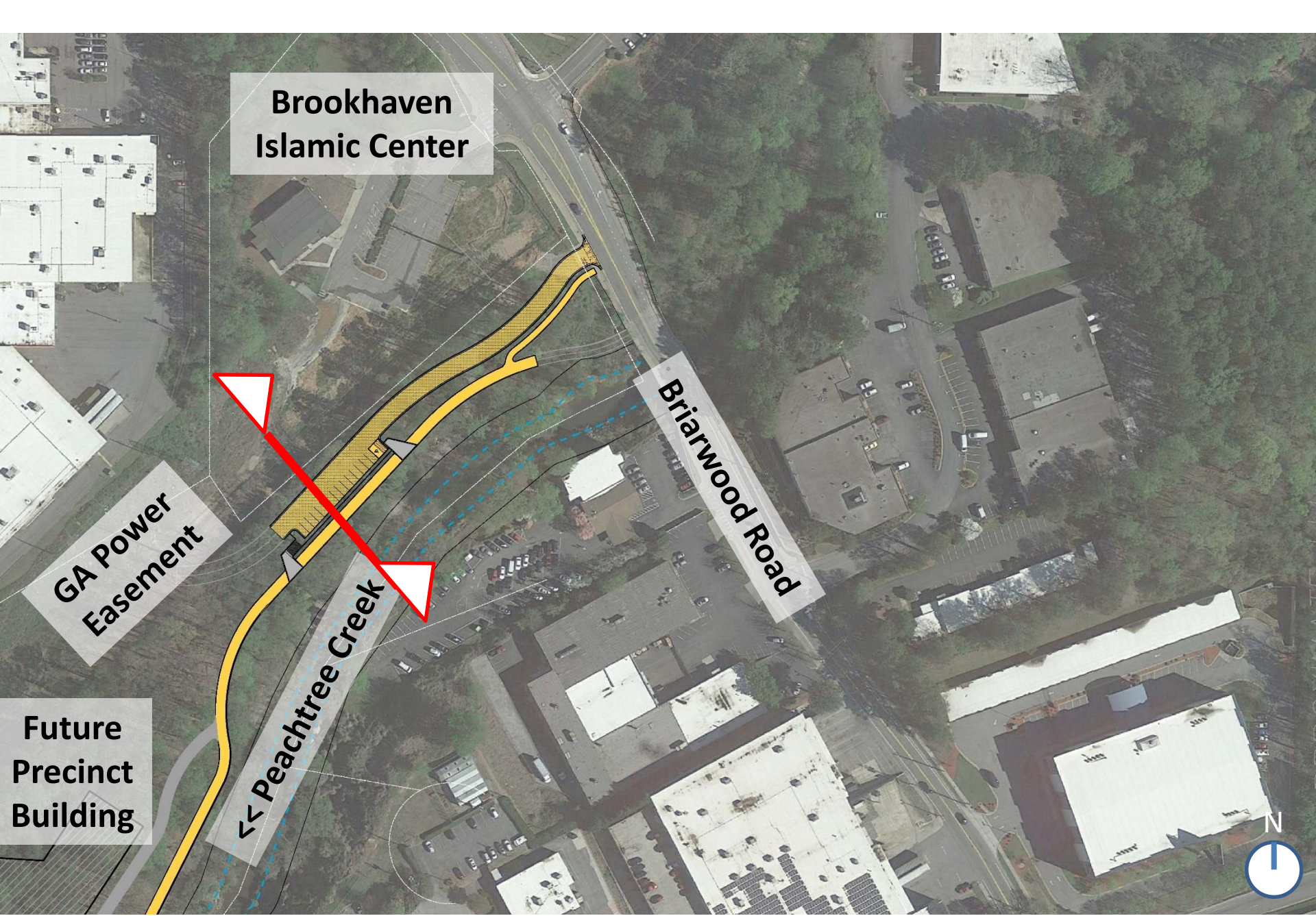

**Brookhaven
Islamic Center**

**GA Power
Easement**

Briarwood Road

←← Peachtree Creek

**Future
Precinct
Building**



Briarwood Road Trailhead – Section

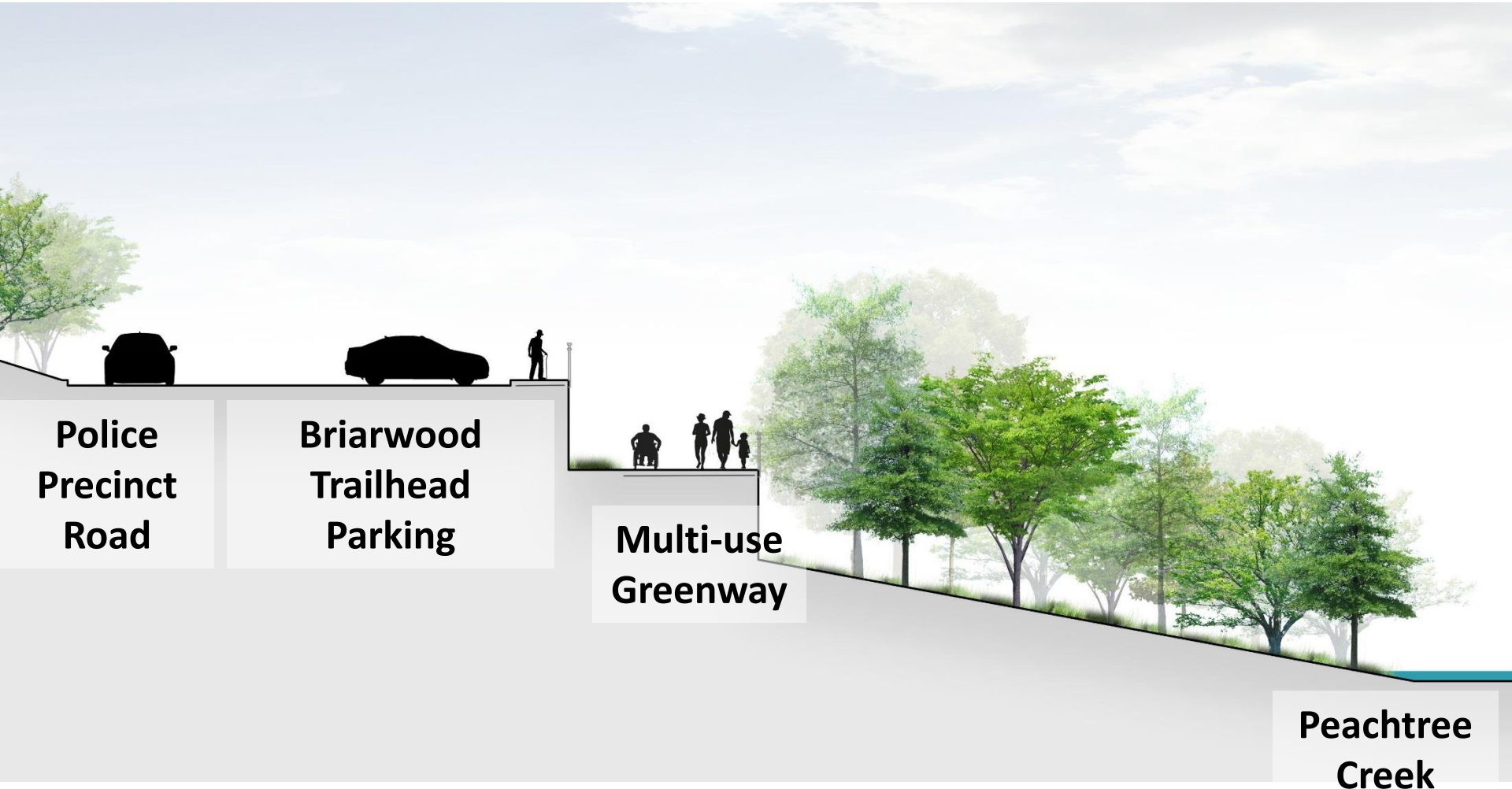

**Police
Precinct
Road**

**Briarwood
Trailhead
Parking**

**Multi-use
Greenway**

**Peachtree
Creek**

Lighting and Custom Handrail

Trail Lighting



MSA MESA LED

1-6 LightBARs
Solid State LED

DECORATIVE LUMINAIRE

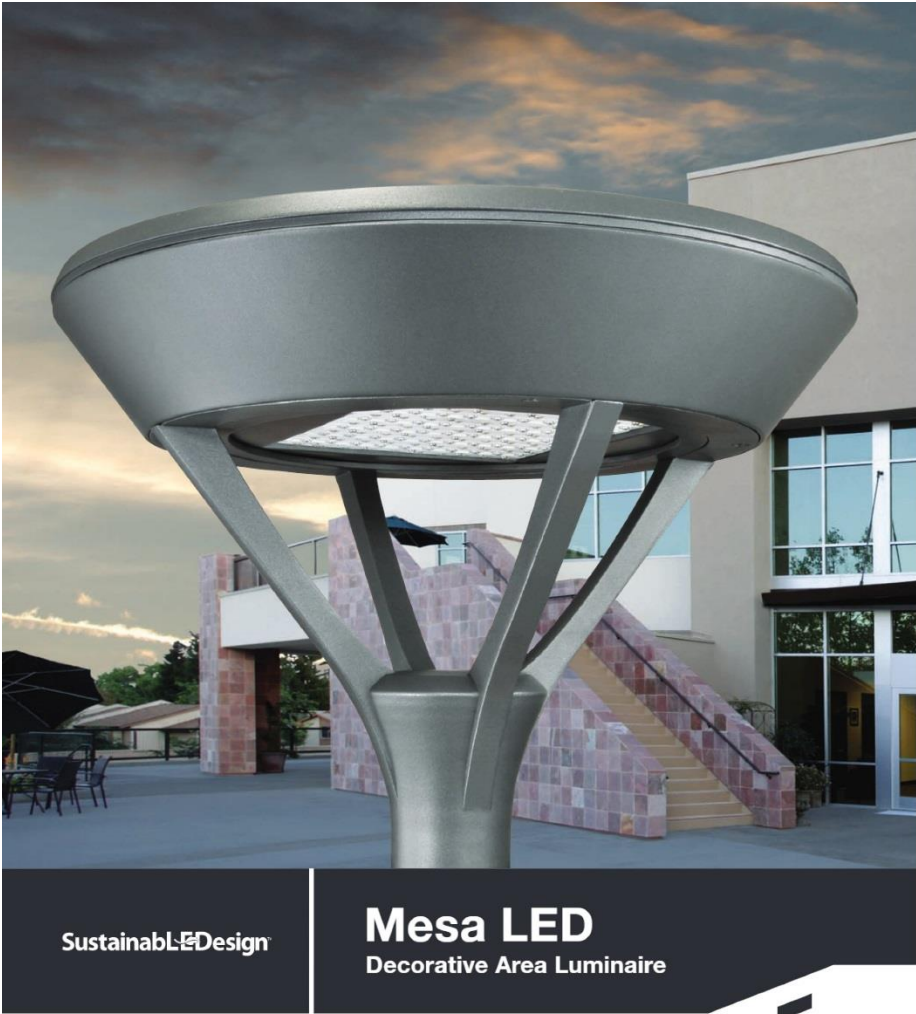

Sustainable Design

Mesa LED
Decorative Area Luminaire

COOPER Lighting

Bridge Handrail

NOTE: CONTRACTOR TO SUBMIT SHOP DRAWINGS FOR FINAL HANDRAIL SPECIFICATIONS WITH CAPITAL SIGNS OR APPROVED EQUAL.

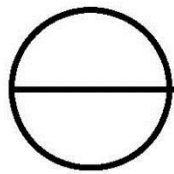
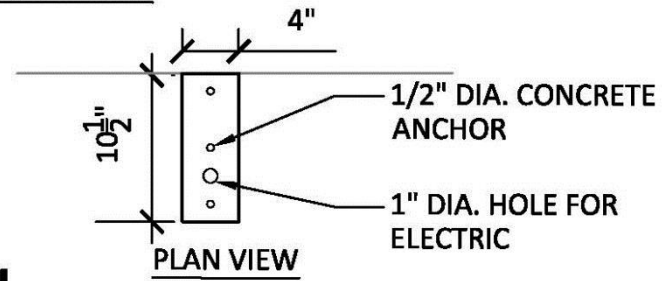
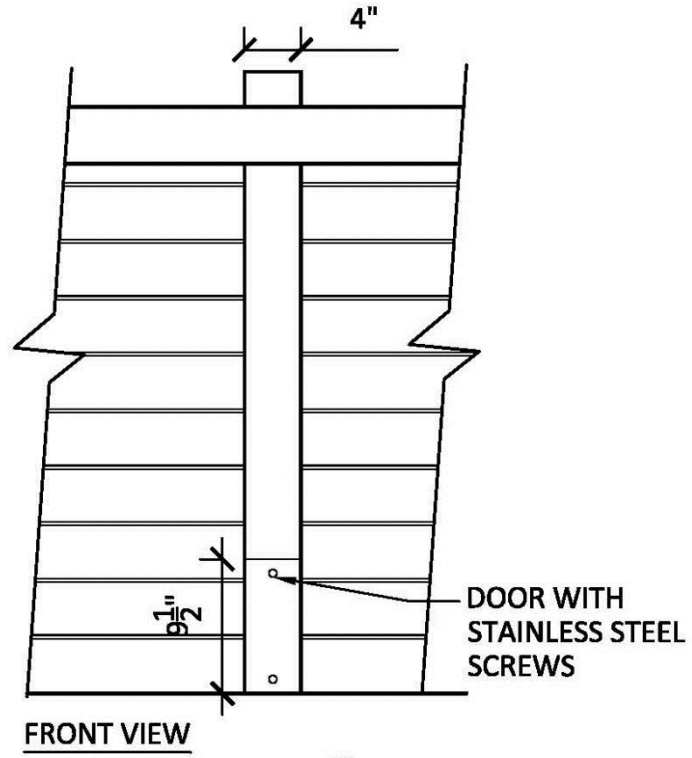
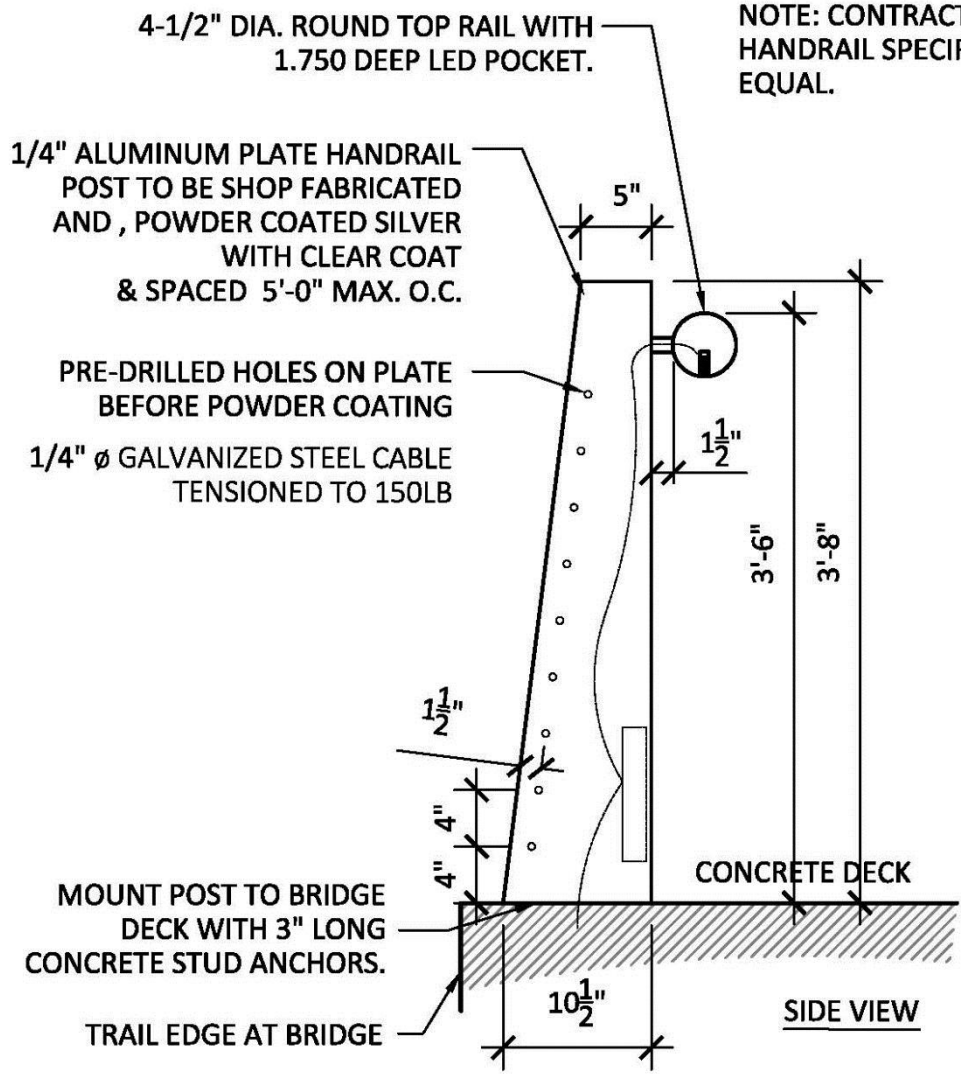

CUSTOM HANDRAIL DETAIL

SCALE: 1" = 1'-0"

Bridge Lighting

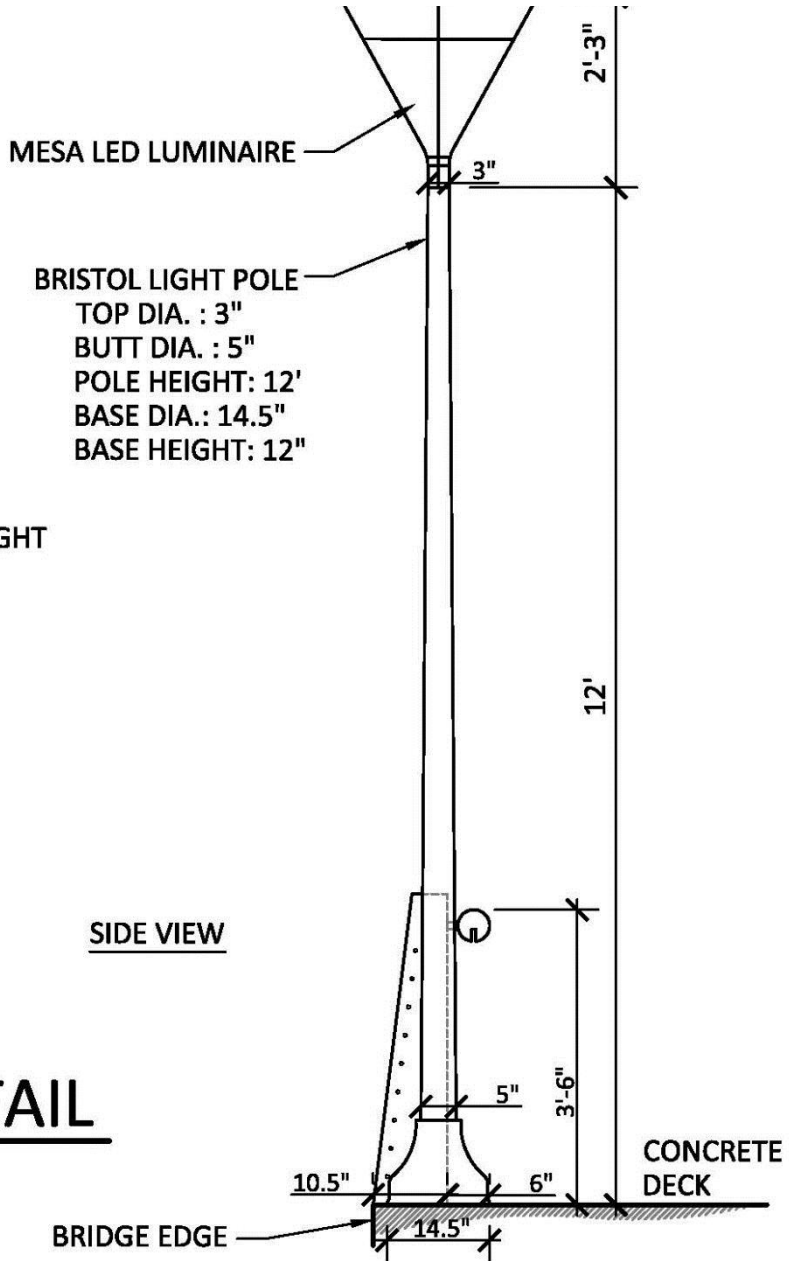
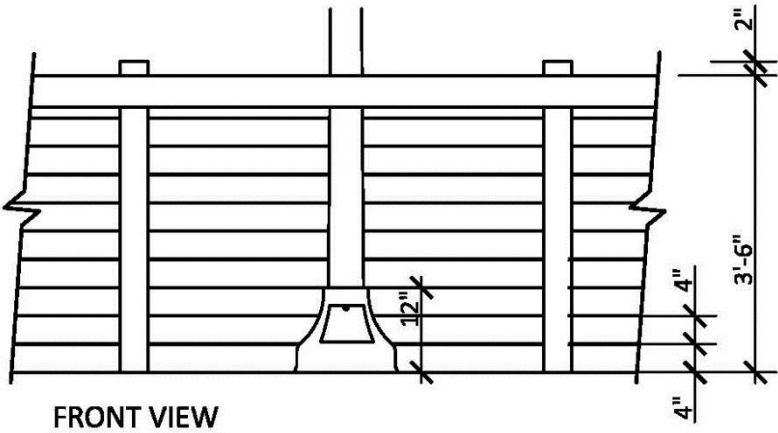
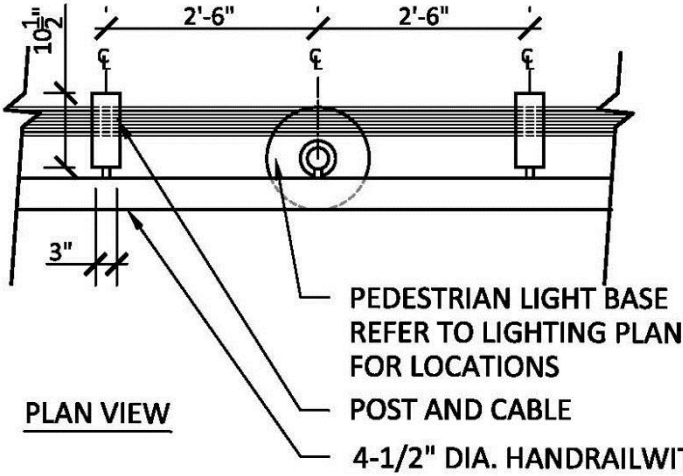

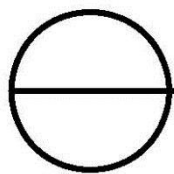
 **BRIDGE LIGHTING DETAIL**
SCALE: 1/2" = 1'-0"

Signage and Amenities

Kiosk Sign with LED Light

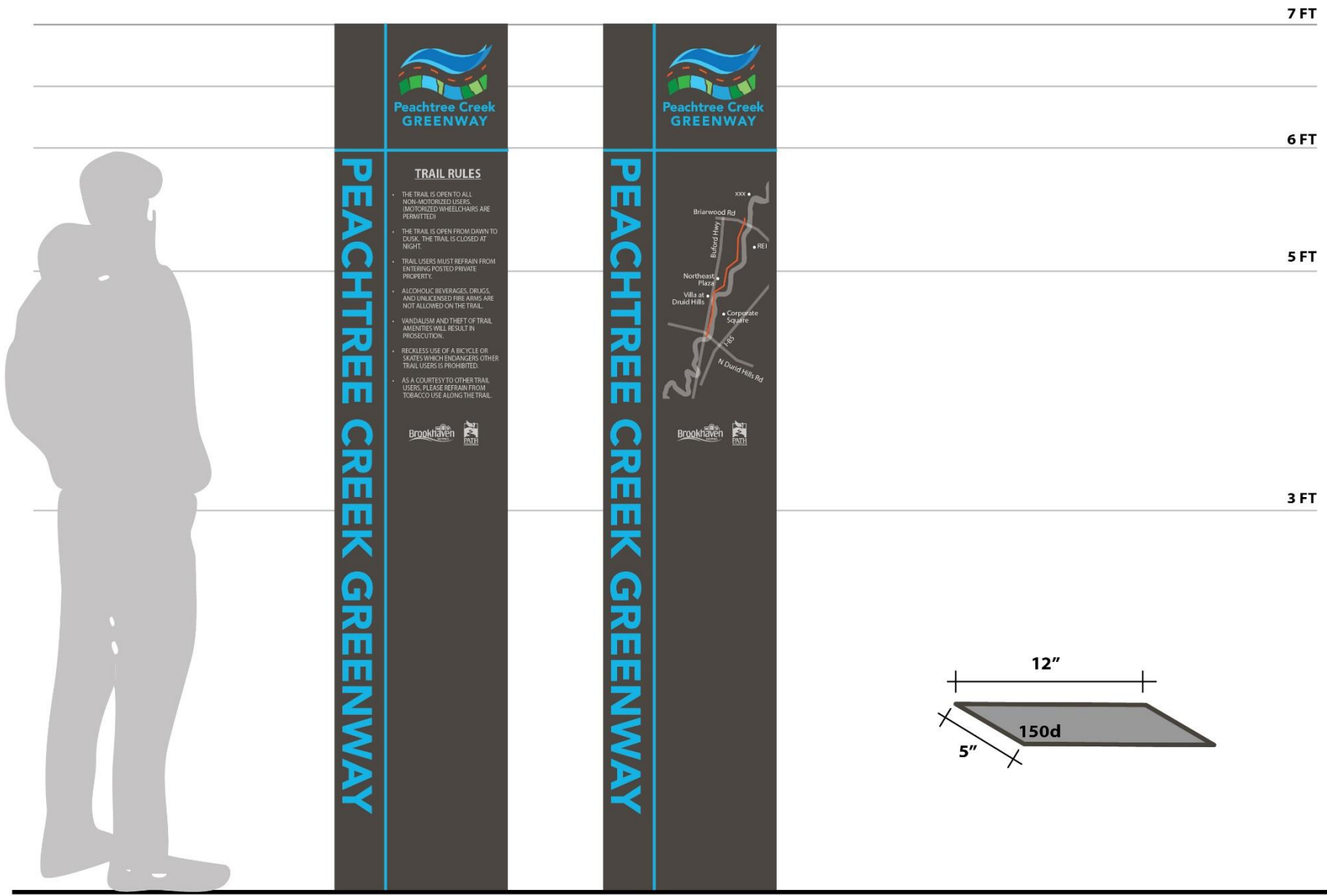

PEACHTREE CREEK GREENWAY

PEACHTREE CREEK GREENWAY

TRAIL RULES

- THE TRAIL IS OPEN TO ALL NON-MOTORIZED USERS. (MOTORIZED WHEELCHAIRS ARE PERMITTED)
- THE TRAIL IS OPEN FROM DAWN TO DUSK. THE TRAIL IS CLOSED AT NIGHT.
- TRAIL USERS MUST REFRAIN FROM ENTERING POSTED PRIVATE PROPERTY.
- ALCOHOLIC BEVERAGES, DRUGS, AND UNLICENSED FIRE ARMS ARE NOT ALLOWED ON THE TRAIL.
- VANDALISM AND THEFT OF TRAIL AMENITIES WILL RESULT IN PROSECUTION.
- RECKLESS USE OF A BICYCLE OR SKATES WHILE ENDANGERS OTHER TRAIL USERS IS PROHIBITED.
- AS A COURTESY TO OTHER TRAIL USERS, PLEASE REFRAIN FROM TOBACCO USE ALONG THE TRAIL.

PEACHTREE CREEK GREENWAY

PEACHTREE CREEK GREENWAY

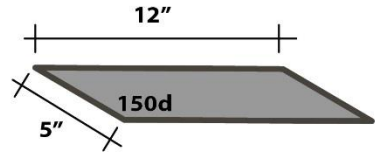

FRONT VIEW

BACK VIEW

PLAN VIEW

Kiosk Sign with LED Light



Amenities

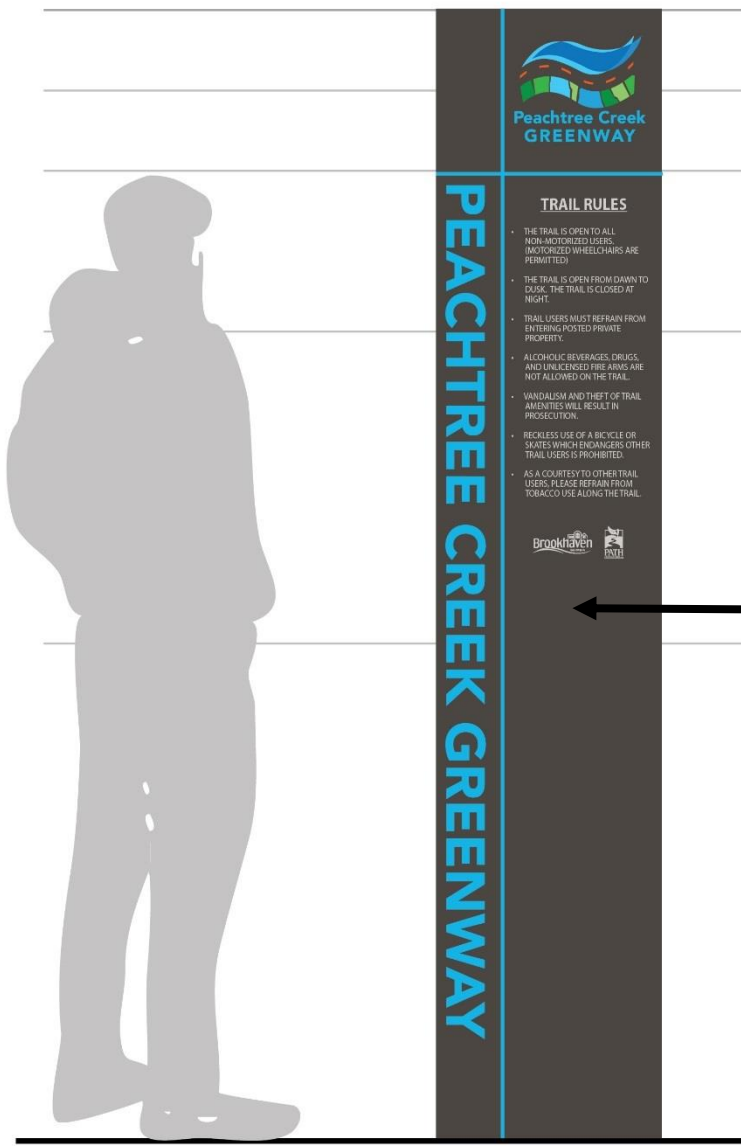

PEACHTREE CREEK GREENWAY



TRAIL RULES

- THE TRAIL IS OPEN TO ALL NON-MOTORIZED USERS. (MOTORIZED WHEELCHAIRS ARE PERMITTED)
- THE TRAIL IS OPEN FROM DAWN TO DUSK. THE TRAIL IS CLOSED AT NIGHT.
- TRAIL USERS MUST REFRAIN FROM ENTERING POSTED PRIVATE PROPERTY.
- ALCOHOLIC BEVERAGES, DRUGS, AND UNLICENSED FIRE ARMS ARE NOT ALLOWED ON THE TRAIL.
- VANDALISM AND THEFT OF TRAIL AMENITIES WILL RESULT IN PROSECUTION.
- RECKLESS USE OF A BICYCLE OR SKATES/WHICH ENDANGERS OTHER TRAIL USERS IS PROHIBITED.
- AS A COURTESY TO OTHER TRAIL USERS, PLEASE REFRAIN FROM TOBACCO USE ALONG THE TRAIL.



Sign Base Color

FRONT VIEW



Directional Sign

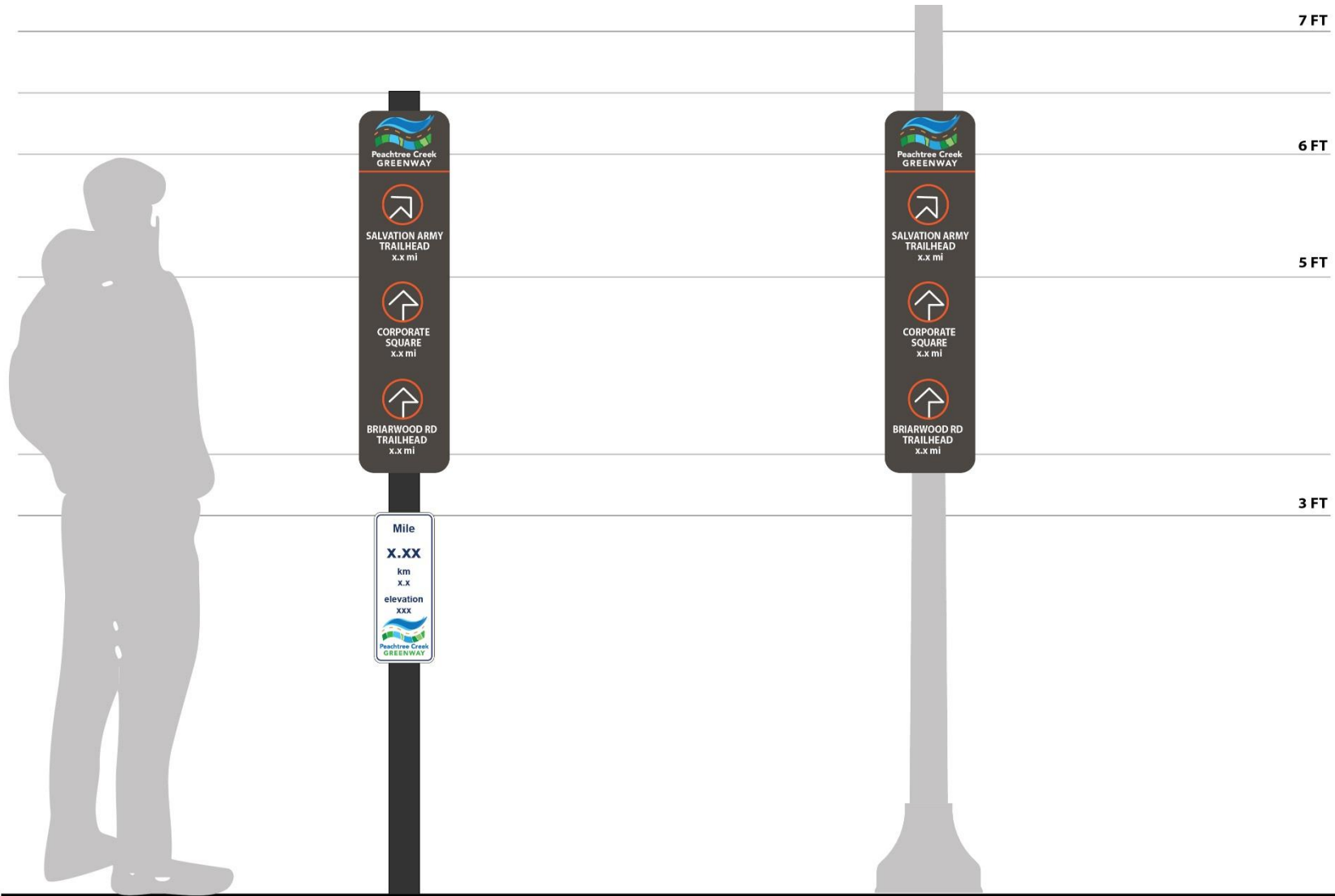

ON SIGN POST

ON LIGHT POST

DIRECTIONAL SIGN

Regulatory Sign

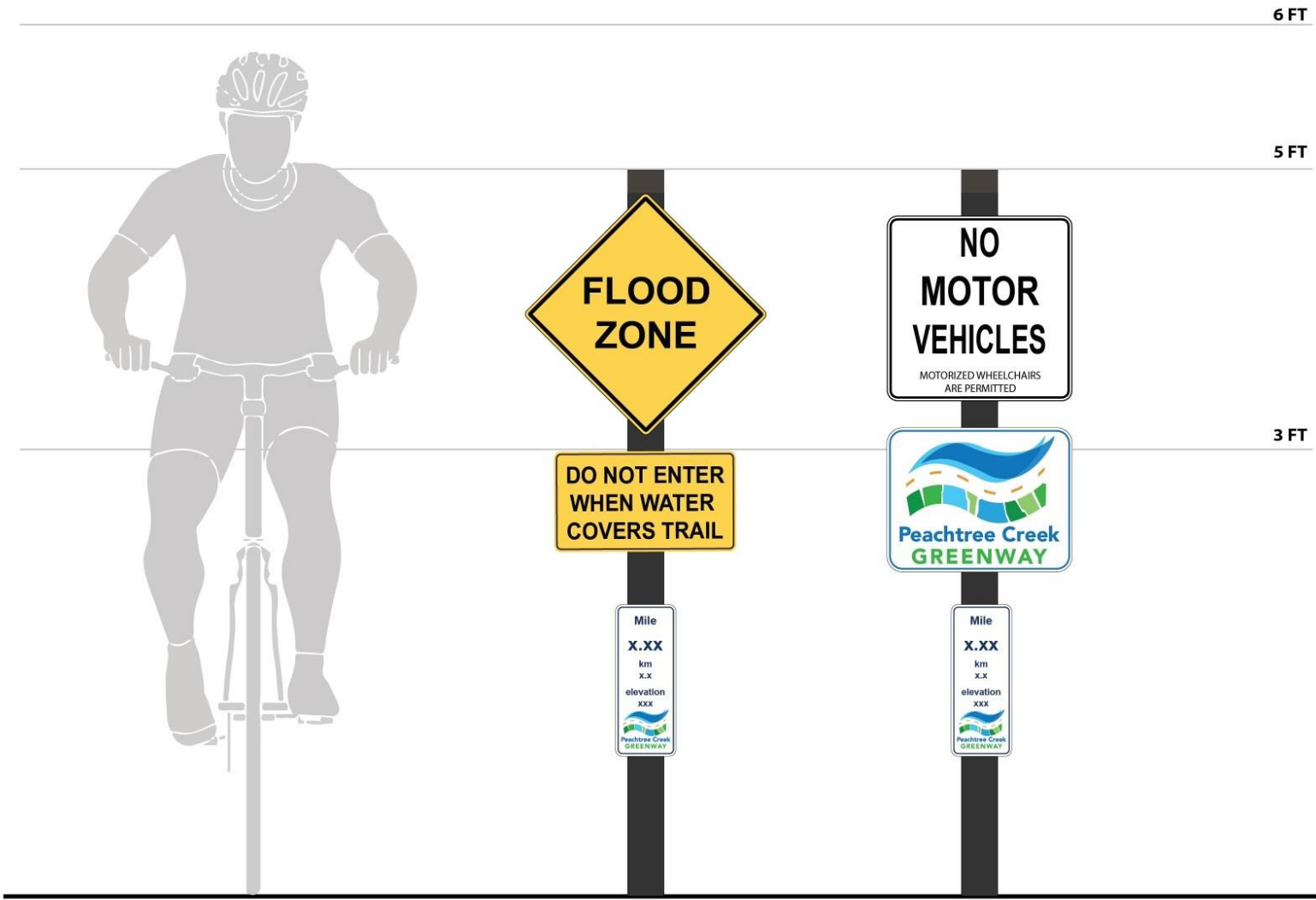

FRONT VIEW

BACK VIEW

REGULATORY SIGN