

INVITATION TO BID (ITB)

ITB 18-102

Walk 18-104 1294 Old Johnson Ferry Phase 2 to West Nancy Creek Rd

Invitation to Bid Due: April 12, 2018 @ 2:00 p.m. EST.

Pre-Bid Conference will be held at 1:00 p.m., March 29, 2018

Location:

City of Brookhaven City Hall

4362 Peachtree Road

Brookhaven, GA 30319

Deadline for Questions: March 29, 2018 at 5:00pm

Questions must be directed to:

City of Brookhaven via e-mail: purchasing@brookhavenga.gov

Questions will only be accepted via email to ensure the same information is given to everyone. A questions addendum will be issued shortly after the deadline and posted on the City's Purchasing Page.

Instructions to Proposers

All spaced below are to be completed and the Invitation to Bid Letter page must be signed where indicated. Failure to sign and return Invitation to Bid Letter may cause rejection of the Invitation to Bid.

Invitation to Bid of:

Company Name: _____

Contact Name: _____

Address: _____

Telephone: _____ Facsimile: _____

Email: _____

Submit Invitation to Bid (ITB) to:
City of Brookhaven Purchasing Office

Invitation to Bid (ITB) shall be presented in a sealed opaque envelope with the bid number and name ITB 18-102 (Walk 18-104 1294 Old Johnson Ferry Phase 2) clearly marked on the outside of the envelope. The name of the company or firm submitting a bid should also be clearly marked on the outside of the envelope. ONE (1) ORIGINAL PAPER COPY AND ONE DISK/FLASH DRIVE OF THE BID MUST BE SUBMITTED.

SCOPE OF SERVICES

The Contractor shall provide the necessary machinery, tools, apparatus, other means of construction, and all materials and labor specified in the Contract Documents or as necessary to complete the City of Brookhaven Project WALK 18-104 Old Johnson Ferry Rd Sidewalk Project, as per the attached layouts and descriptions.

Unless otherwise directed, all work performed shall be in accordance with the Georgia Department of Transportation *Standard Specifications, Construction of Transportation Systems* (current edition). All materials used in the process of completion of the work included in the Contract will be furnished from Georgia Department of Transportation certified suppliers only.

There is no City furnished equipment to be installed by the Contractor.

WALK 18-104

Old Johnson Ferry Rd (1294 Old Johnson Ferry Rd to West Nancy Creek Rd):

The Walk 18-104 Old Johnson Ferry Rd Sidewalk Project is on the north side of Old Johnson Ferry Rd beginning at 1294 Old Johnson Ferry Rd and extends to West Nancy Creek Rd. (See attached location map). The proposed sidewalk will be placed in the existing shoulder, no roadway pavement area will be utilized for sidewalk installation.

Time and Liquidated Damages

The Contractor shall not proceed to furnish such services and the City shall not become obligated to pay for same until a written authorization to proceed (“Notice to Proceed”) has been sent to the Contractor from the City. The Contractor shall commence the Work no later than ten (10) days after the effective date of the Notice to Proceed and shall achieve Substantial Completion of the Work, as hereinafter defined, no later than **45 calendar days**, in accordance with the Contract Documents. The number of calendar days from the date on which the Work is permitted to proceed, through the date set forth for Substantial Completion, shall constitute the Contract Time. The Work shall be carried on expeditiously, it being understood, however, that this Agreement may be extended or continued in force by the parties hereto in writing as provided herein.

The Contractor shall pay the City the sum of **\$500.00** per day for each and every calendar day of unexcused delay in achieving Substantial Completion beyond the date set forth herein for Substantial Completion of the Work. Any sums due and payable hereunder by the Contractor shall be payable, not as a penalty, but as liquidated damages representing an estimate of delay damages likely to be sustained by the City, estimated at or before the time of executing this Contract. When the City reasonably believes that Substantial Completion will be inexcusably delayed, the City shall be entitled, but not required, to withhold from any amounts otherwise due the Contractor an amount then believed by the City to be adequate to recover liquidated damages applicable to such delays. If and when the Contractor overcomes the delay in achieving Substantial Completion, or any part thereof, for which the City has withheld payment, the City shall promptly release to the Contractor those funds withheld, but no longer applicable, as liquidated damages.

Substantial Completion

Substantial Completion shall mean that stage in the progression of the Work when the Work is sufficiently complete in accordance with this Contract that the City can enjoy beneficial use and occupancy of the Work and can utilize the Work for its intended purpose. Partial use or occupancy of the Project shall not result in the project being deemed substantially complete, and such partial use or occupancy shall not be evidence of Substantial Completion.

Time is of the Essence

All limitations of time set forth in the Contract Documents are of the essence of this Contract.

Project Scope

This is a lump sum not to exceed project and will include but not be limited to; the construction of approximately 1000 linear feet of five-foot wide concrete sidewalk with one pedestrian landing (handicap ramp); the raising of approximately 700 linear feet of existing granite curb; repair any landscape damages to match existing (e.g. replace with sod); any clearing, grading, or tree/root removal necessary to complete the work; & the replacement of existing catch basin top with new single wing top (See GDOT Standard: 1033F). The proposed sidewalk will vary between 2' – 5' behind the existing curb to avoid existing mailboxes, power poles, & additional obstacles as directed by engineer. Driveways are to be modified to meet sidewalk ADA standards as required and/or directed by the engineer. The Contractor shall contact and coordinate any driveway construction with associated property owner. The proposed sidewalk will utilize existing right-of-way area to place sidewalk along granite curb. See layout.

The attached layout may be adjusted to accommodate field conditions as needed by the Engineer.

There will be pay items for up to 556 square yards of sidewalk, 38 square yards of existing sidewalk removal, 400 square yards of sod to be installed as directed by the Engineer. Placement of up to 75 tons of GAB as a foundation for the adjustment of existing granite curb. Approximately 700 LF of existing granite curb will need to be raised and adjusted to minimum height requirements (6 inches). Please refer to the bid schedule for specific quantities.

Project Scope shall include but is not limited to:

1. Site layout to include marking sidewalk path for City approval. Site preparation for sidewalk to include excavation and removal or import of material within construction site.
2. The per unit pay items shall include all clearing and grading work, permanent grassing of disturbed areas not sodded, any work required under the special provisions, all necessary erosion control, and all work called out in the plans or specifications. Grading of sidewalk & adjacent slopes to 2:1 or less as directed by the Engineer.
3. Site preparation for existing driveways to include excavation and removal or import of material for their replacement as specified by the Engineer.
4. Coordination with property owners to ensure adequate access to all properties.
5. Adequate care shall be taken by the Contractor to insure the existing granite curb is adjusted in a manner to which the curb is not damaged and is in a reusable condition. City has limited supply of granite curb that can be provided to the contractor to replace any damaged existing curb that cannot be reset. The Contractor will be responsible for loading and delivering city supplied granite. **No** additional claims will be considered for providing replacements for damaged blocks.
6. Traffic control in accordance with City & MUTCD standards as well as removal and reset of traffic signage.
7. Installation & maintenance of erosion control devices to include daily covering of any disturbed areas with straw mulch as well permanent grassing up to ¼ acre, in addition to sod placement.
8. Undercut excavation necessary to achieve appropriate compaction.
9. The contractor shall irrigate of newly installed landscaping minimum of six times, as direct by Engineer.

10. All testing of materials shall be in accordance with GDOT specifications.
11. Disturbed areas shall receive permanent stabilization if not sodded or stabilized as directed by the engineer. If grassing activities are not in season, then rye grass or grassing as directed by the engineer will be utilized. Once grassing is in season, the area will be prepared and reseeded with permanent grassing.
12. Any irrigation facilities and yard lights damaged during the course of project activities shall be repaired and the contractor shall coordinate with the facility owner.
13. The contractor will coordinate corresponding appropriate utility companies to remove and reset tension wires in conflict with the proposed sidewalk/structures.
14. The contractor is responsible for the removal of any utility markers in conflict of the proposed sidewalk/structures.
15. Trees within the project area will be pruned to a height of 14 feet along Old Johnson Ferry Rd or as directed by the engineer. Trees placed for landscaping purposes are to be excluded as directed by the engineer. Any trees removal performed during the course of the project will include stump removal or grinding as part of the work.

General Notes:

1. The contractor is responsible for calling for utility locations prior to the start of the project. It shall be the contractor's responsibility to coordinate his work with any utility owner whom maybe in conflict with his work. No claims will be considered for extra compensation.
2. Any item which must be removed during the construction work and is not specially called for shall be removed by the contractor. The cost shall be included in the project complete pay item. No claims will be considered for extra compensation.
3. All traffic control shall be provided by the contractor in accordance with the MUTCD.
4. It is the intent of this contract for each unit price bid to include all labor, materials, equipment, tools, transportation, and supplies as required as necessary to complete the work in accordance with the plans, specifications as directed, and the terms of this contract.
5. The general descriptions of each item of work are as described in the Georgia Department of Transportation's standards and specifications, complete and accepted. Any conflicts which might occur during the course of the construction work or any conflicts which might be related to the compensation of any work shall be decided based on the Georgia DOT's standards and specifications. No claims will be considered for extra compensation.
6. Upon the completion of each project, any excess items which might be left over from the construction related work shall be removed and disposed of properly by the contractor. The cost for such removal and disposal of such items will be included in the project complete pay item. No claims will be considered for extra compensation.
7. Under this scope, "Department", "Engineer", and "Resident Engineer" shall mean the "City of Brookhaven, Georgia, Public Works Director or City of Brookhaven, Georgia, Public Works Designee".
8. Working hours are expected to be Monday through Friday, 8:00 A.M. to 5:00 P.M. except where otherwise noted. Lane closures are limited to the hours of 9:00 A.M to 4:00 P.M. No work is permitted on city-observed holidays.
9. Contractor shall have all vehicles marked with their company name.
10. The contractor will conduct, at Brookhaven City Hall, one overall contract pre-construction meeting

shortly after award of the contract and other meetings as required. The City may at its discretion require meetings between the contractor superintendent and the Engineer to be held once a week with two week schedule look-a-heads or additional meetings to ensure project execution.

11. Any quantities of any of the pay items in the bid schedule of the contract that exceed the plan quantities will be installed on an as needed basis, as directed by the engineer.
12. The contractor will provide video and pictures of the project area before the project begins and after the project is complete. The video and pictures will be provided to the City once it is complete in an acceptable format.
13. Wheelchair ramp installation shall be included as a part of the sidewalk pay item.
14. The City of Brookhaven will not provide restroom facilities.
15. The Contract shall perform project housekeeping/clean-up on a daily basis. A 24-hour contact must be provided to the City of Brookhaven Call Center for all issues as needed in regard to the project for any safety, signage, erosion control, or other emergency as needed.
16. The Contractor's performance will be measured based on the following:
 - Compliance with the Scope of Work
 - Meeting the agreed upon schedule dates
 - Submission of all deliverables as specified
17. All non-lump sum items will be paid for at the contract unit price for what is complete, in place, & accepted on the project by the engineer. Measurement & payment of contract pay items will follow GDOT specifications.
18. This is a linear project located in an established neighborhood. There is not a proposed staging area.

This bid will require bonds. Please see bonding documents at the end of this procurement.



- Legend**
- Street Label
 - Address Points
 - Buildings**
 - Rule_1
 - Buildings**
 - Rule_1
 - Sidewalk
 - City of Brookhaven
 - TaxParcel
 - Lake
 - Creek or Stream
 - Proposed Sidewalk
 - Affected Parcels

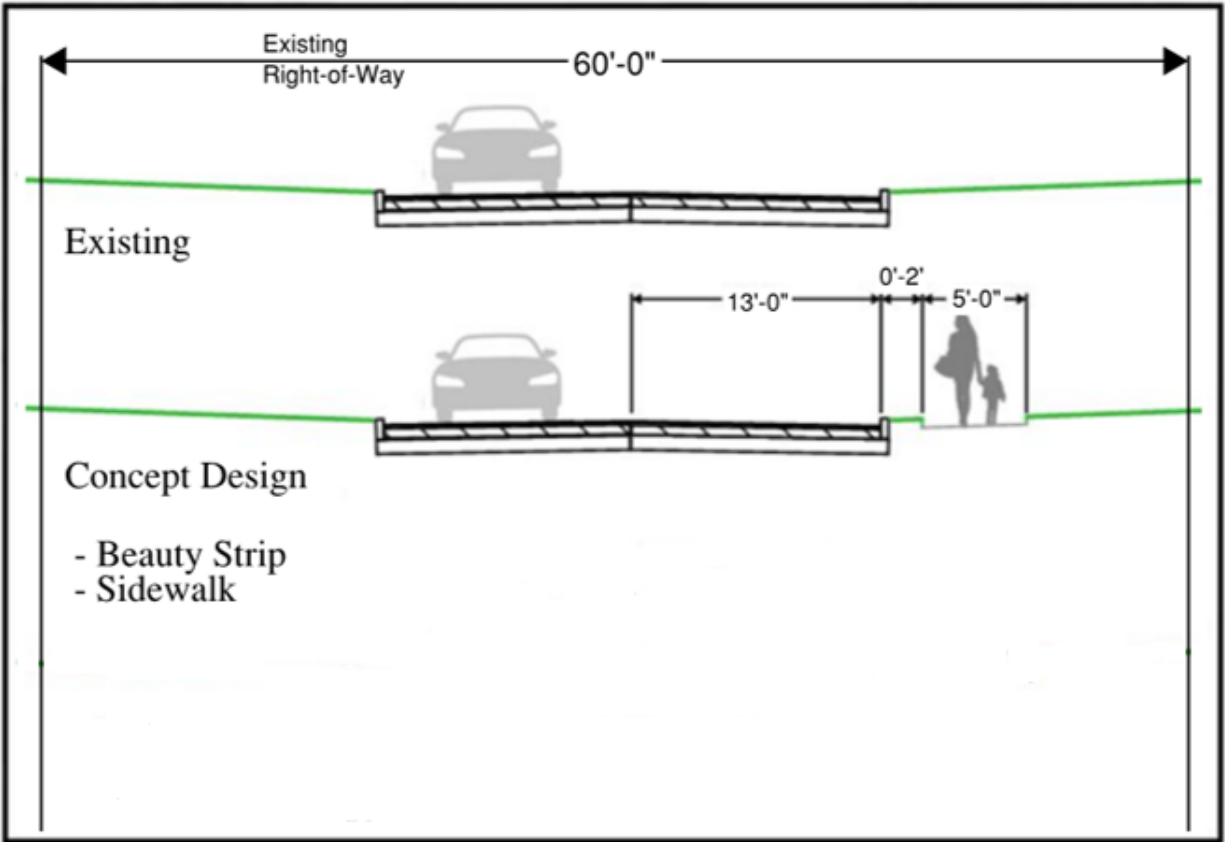

Typical Section



Figure 1: Utility Pole and Tree to work around (east termini).













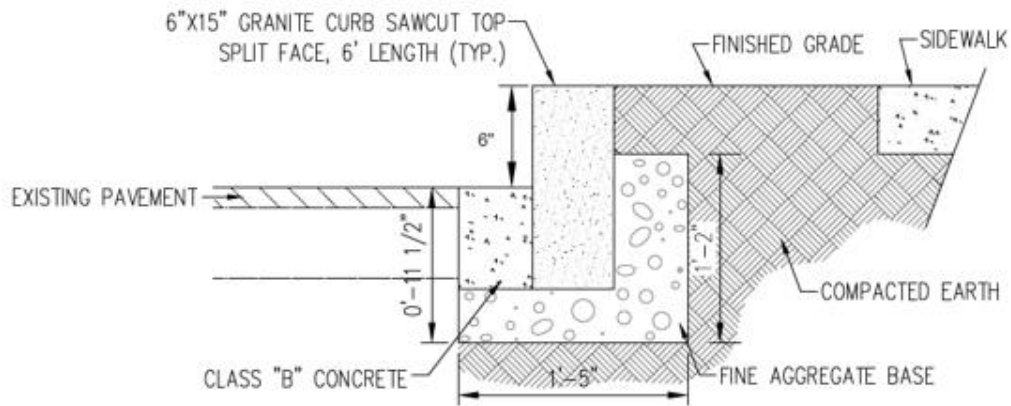

**6" GRANITE CURB
DETAIL**

SCALE: NONE

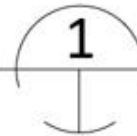

**CITY OF BROOKHAVEN
PUBLIC WORKS DEPARTMENT**

GRANITE CURB DETAIL

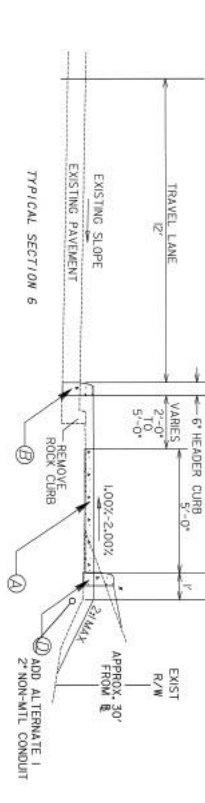
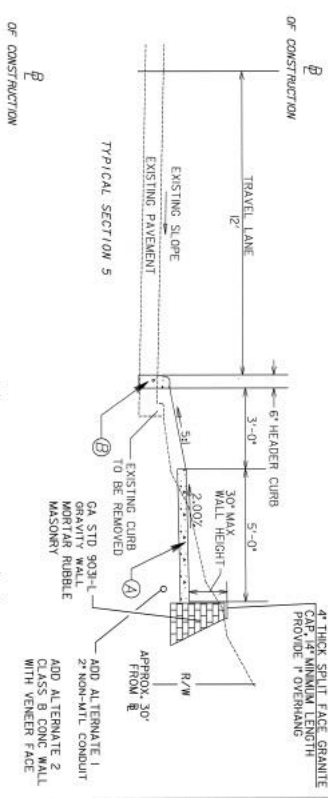
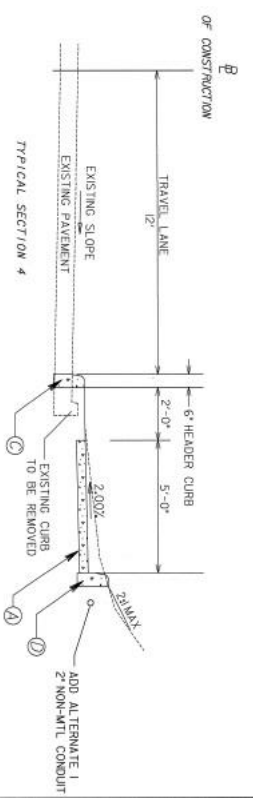
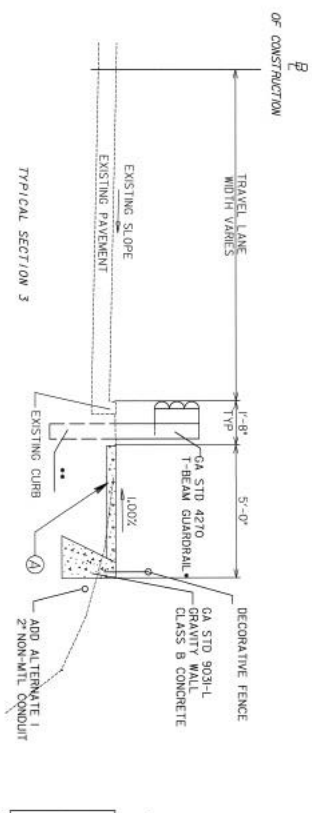
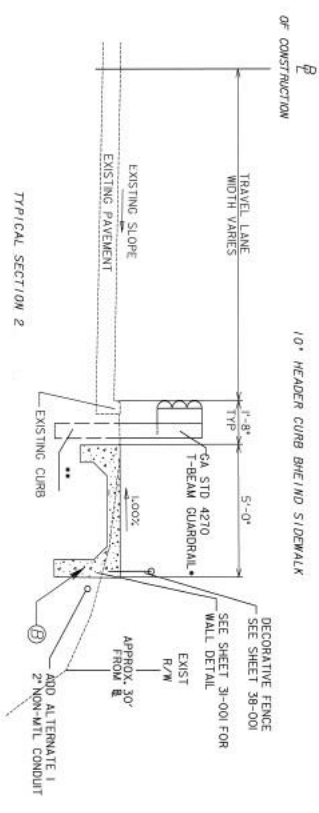
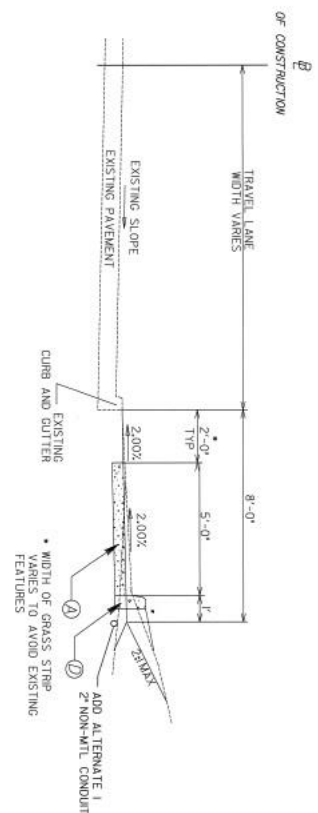

- REPLACE BROKEN SIDEWALK PANELS**
- LEGEND**
- ① CONCRETE SIDEWALK ***
 - ② CLASS B CONCRETE INCLUDING REINFORCING STEEL
 - ③ 6" TYPE 2 HEADER CURB
 - ④ 10" TYPE 4 HEADER CURB
- *** HANDICAP RAMPS SHALL BE 6" SIDEWALK CONCRETE

NOTES: SOD ALL DISTURBED AREAS TO BE PAID FOR UNDER GRASSING COMPLETE. BASELINE IS FOR INFORMATION ONLY. SIDEWALK LOCATIONS SHALL BE BASED OFF OF BACK OF CURB UNLESS OTHERWISE NOTED. TRIM ALL TREE LIMBS TO PROVIDE AN 8" VERTICAL CLEARANCE ABOVE THE PROPOSED SIDEWALK.

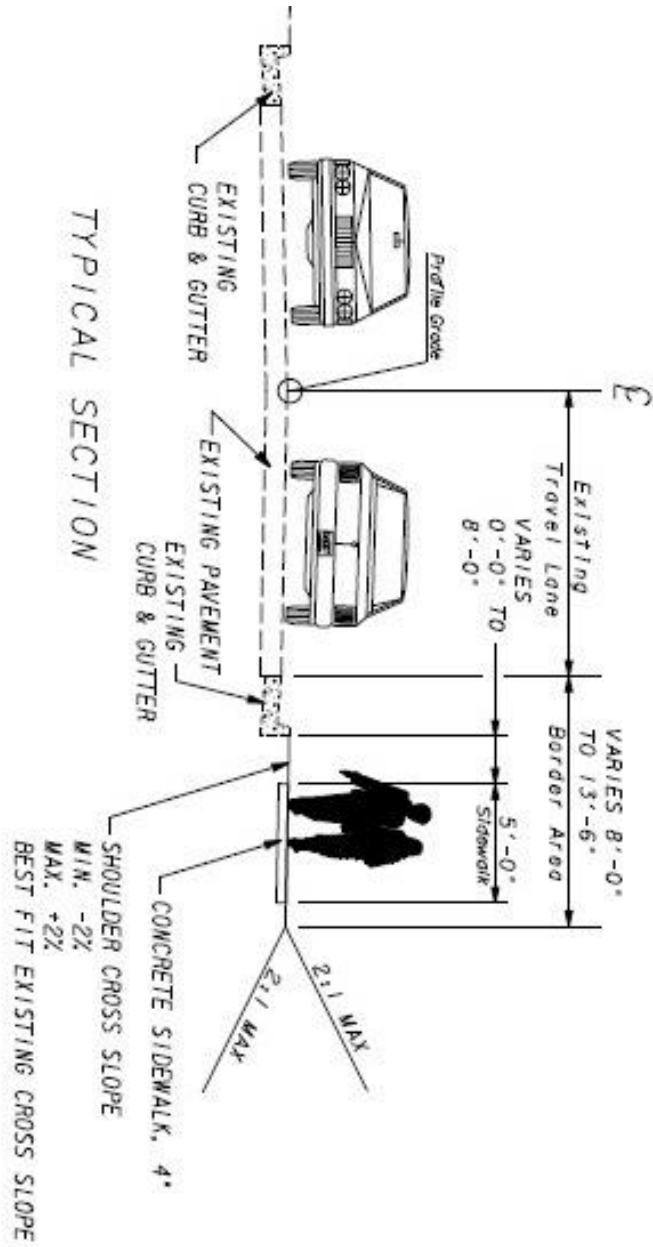

Handicap Ramp Standards

TYPICAL LOCATIONS FOR CURB CUT RAMPS - PLAN VIEW

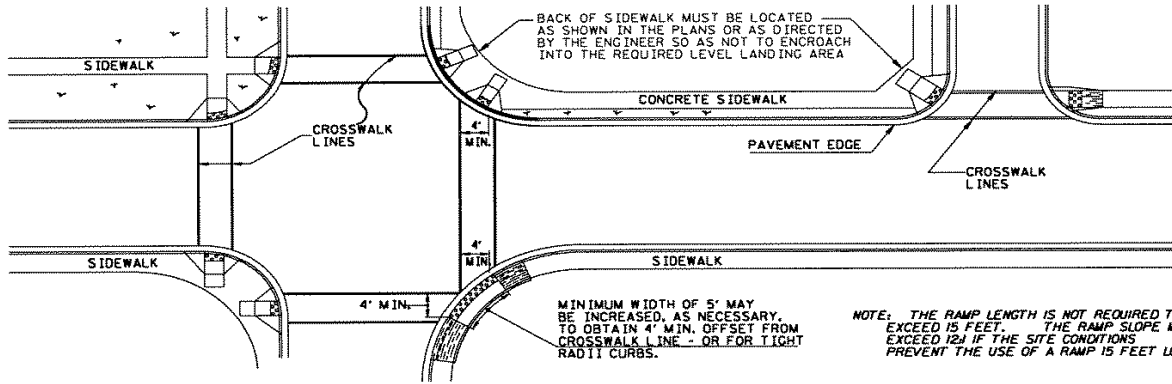

Type A
(The Preferred Ramp)

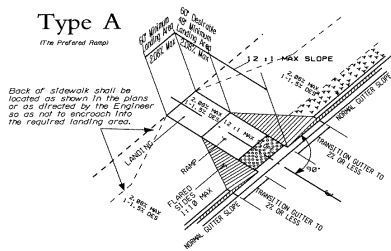

Type B

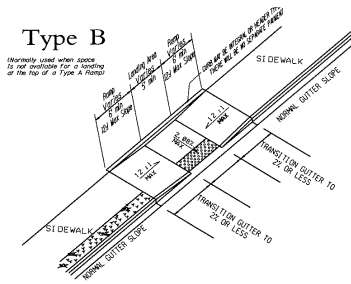

Type D

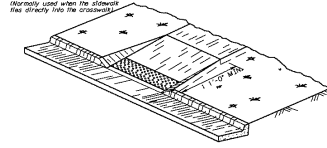

IN AREAS WHERE THE GUTTER HAS A SLOPE OF 1 IN 4, END NORMAL GUTTER SLOPE AT A DISTANCE OF 6 TO 10 FEET FROM THE RAMP AND BEGIN TRANSITION TO A 1.5% BOTTOM SLOPE. NORMAL GUTTER SLOPE SHALL BE RESUMED AT A SIMILAR DISTANCE BEYOND THE RAMP.

Type C

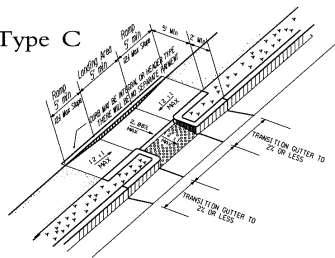

Skewed Ramp Details
(Applies to Type A & Type D Ramps Only)

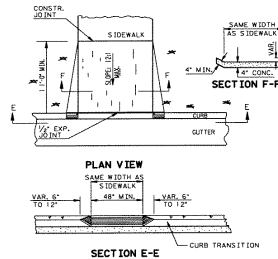
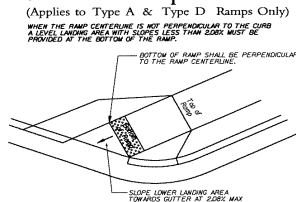

Catch Basin Standard

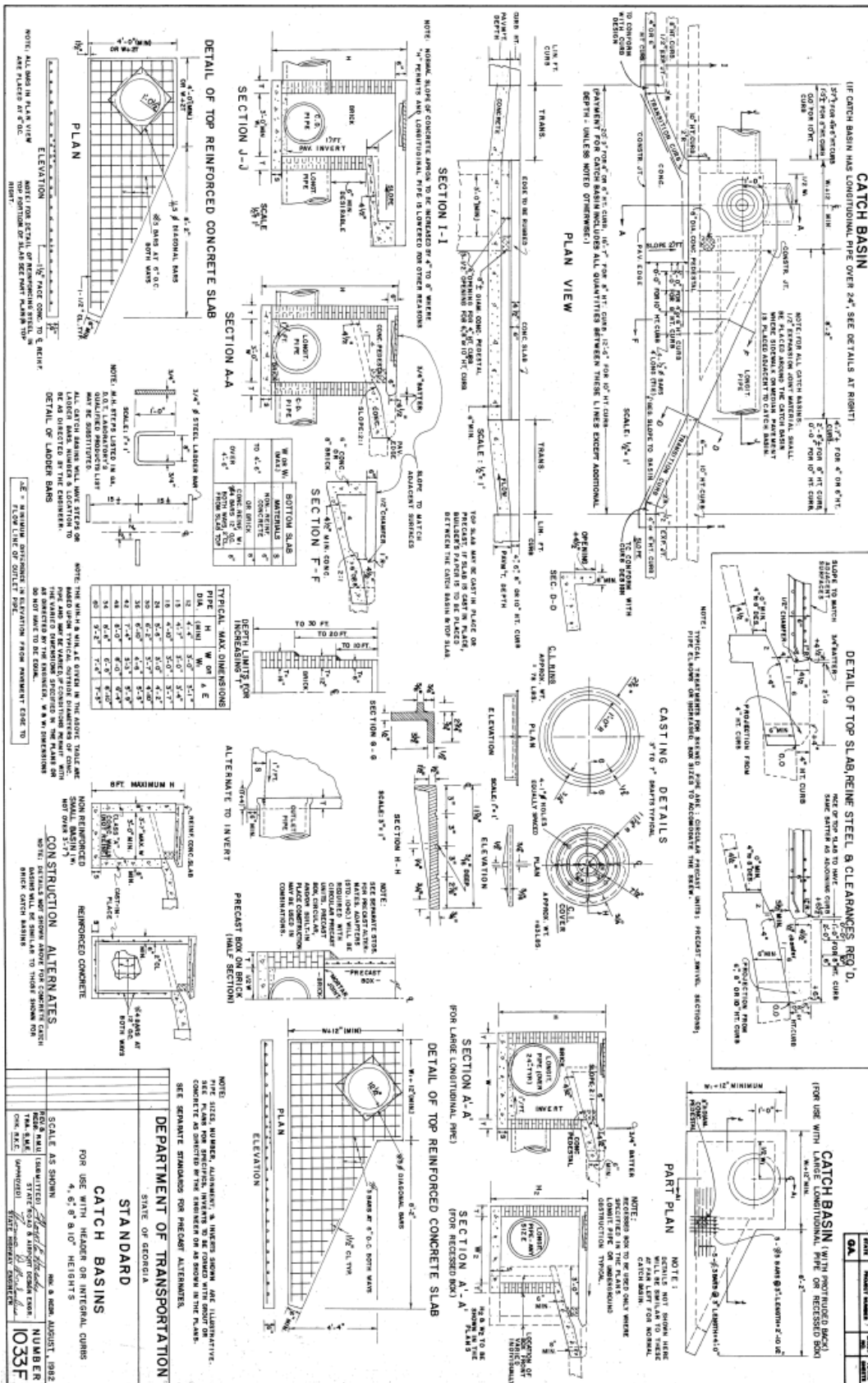



Erosion Control Details

Sd1-A Type A Silt Fence

Sd1-A	SILT FENCE TYPE A		<p>USED FOR CHECK DAMS, ALONG THE TOE OF FILLS OVER 10' HIGH, ALONG THE RIGHT OF WAY LINE OR PARALLEL TO STREAMS. THE FENCE SHOULD NEVER RUN CONTINUOUS. IT SHOULD TURN BACK INTO THE FILL TO CREATE SMALL POCKETS TO TRAP SILT. WHEN USED AS DITCH CHECK DAM THE SPACING IS, 100 FEET FOR SLOPES 1% TO 2%; AND 50 FEET FOR 2% TO 3% SLOPES. THE SPACING SHOWN SHOULD BE DECREASED FOR HIGH FILLS AND LONG DITCHES.</p>
	CONSTRUCTION DETAIL SECTION 171		
	— A — A — A — Sd1-A — A — A — A —		

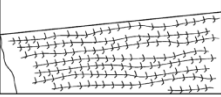
Ds1 Disturbed Area Stabilization with Mulching Only

Ds1	MULCH		<p>THIS IS AN APPLICATION OF STRAW MULCH USED TO REDUCE SOIL EROSION AND STABILIZE THE SOIL. IT IS USED TO CONTROL EROSION IN AREAS WHERE PERMANENT VEGETATION IS OUT OF SEASON OR TO TEMPORARILY STABILIZE AREAS PRIOR TO FINAL GRADING.</p>
	SECTION 163		
			

Sd2 Straw Bales as Inlet Sediment Trap

Sd1-Hb	SEDIMENT BARRIER		<p>A BARRIER OF BALED STRAW IS USED TO PREVENT SEDIMENT FROM LEAVING THE CONSTRUCTION SITE. IT IS USED IN DITCHES AS DITCH CHECKS OR ALONG THE TOE OF SLOPE OR RIGHT OF WAY IN FILLS LESS THAN 10 FEET HIGH. THE BALES SHOULD RUN PARALLEL TO THE SILT YIELDING AREA UNTIL THE TOP OF THE BALE IS 6 INCHES LOWER THAN THE GROUND ELEVATION OF THE BEGINNING BALE. THEY SHOULD THEN TURN INTO THE FILL WITH A LOW POINT FOR THE WATER TO DRAIN OVER THE BALE. IN DITCHES, BALED STRAW SHOULD BE PERPENDICULAR TO THE FLOW. USED FOR SLOPES LESS THAN 1%, USE 100' SPACING. BALED STRAW SHALL BE STAKED SECURELY TO THE GROUND.</p>
	CONSTRUCTION DETAIL SECTION 163		
	— S — S — S — Sd1-Hb — S — S — S —		

Sd2-F Inlet Sediment Trap

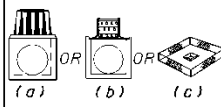
Sd2-F	INLET SEDIMENT TRAP CONSTRUCTION DETAILS SECTION 163	 (a) OR (b) OR (c)	(a) A SEDIMENT BARRIER CONSISTING OF A PREFABRICATED FRAME WITH FILTER FABRIC USED AROUND A DROP INLET OR CATCH BASIN (b) A SEDIMENT BARRIER CONSISTING OF A PERFORATED METAL STAND PIPE WITH FILTER FABRIC USED AROUND A DROP INLET OR CATCH BASIN (c) TYPE C SILT FENCE WITH SUPPORTING FRAME CAN BE USED AS AN ALTERNATE TO INLET SEDIMENT TRAP FOR AREAS WITH SLOPES < 5%
	LINE CODE Sd2-F	THIS ITEM IS USED TO PREVENT SILT FROM ENTERING THE PIPE SYSTEM. SHALL NOT APPLY TO INLETS RECEIVING CONCENTRATED FLOWS. RECOMMENDED FOR INLET RECEIVING FLOWS THAT RANGE FROM 0-0-4 c.f.s.	

Sd1-C Type C Silt Fence

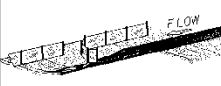
Sd1-C	SILT FENCE TYPE C CONSTRUCTION DETAIL SECTION 171		A WOVEN SYNTHETIC FIBER FABRIC PLACED IN FRONT OF A WIRE FENCE. IT CAN BE USED ALONG THE TOE OF THE FILL, ALONG THE RIGHT OF WAY LINE OR PARALLEL TO STREAMS. IT IS USED TO CAPTURE SEDIMENT FROM FILLS OVER 10 FEET HIGH AND UNDER ALL BRIDGES.
	LINE CODE - C - C - C - Sd1-C - C - C - C -		

Notes

Note 1: Install Best Management Practices alongside sidewalk installation and downgradient of disturbed area (where applicable).

Note 2: All disturbed areas to be stabilized with mulching (Ds 1) at the end of each work day.

BID SCHEDULE

WALK 18-104 Old Johnson Ferry Rd- Phase 2 Sidewalk

Item No.	Description	Estimated Qty	Unit	Unit Price	Total Price
1	TRAFFIC CONTROL	1	LS		
2	GR AGGR BASE CRS, INCL MATL	75	TN		
3	DRIVEWAY CONCRETE, 6 IN TK	175	SY		
4	REMOVE CONC SIDEWALK 4 IN TK	38	SY		
5	CONC SIDEWALK 4 IN TK	556	SY		
6	ADJUST STRAIGHT GRANITE CURB 16 IN, TP A	700	LF		
7	REPLACE CATCH BASIN TOP, 1033F	1	EA		
8	SOD	400	SY		

*** TOTAL BID EXCLUDES CITY CONTROLLED CONTINGENCY*

Total Base Bid Amount: _____

Total Base Bid Amount in Words:

THIS PAGE MUST BE COMPLETED AND SUBMITTED AS A PART OF YOUR BID

INSURANCE REQUIREMENTS

Within 10 days of Notice of Award, and at all times that this Contract is in force, the Contractor shall obtain, maintain and furnish the City Certificates of Insurance from licensed companies doing business in the State of Georgia with an A.M. Best Rating A-10 or higher and acceptable to the City covering:

1. **Workers' Compensation & Employer's Liability Insurance.** Workers' Compensation Insurance in compliance with the applicable Workers' Compensation Act(s) of the state(s) wherein the work is to be performed or where jurisdiction could apply in amounts required by statutes. Employer's Liability Insurance, with limits of liability of not less than \$1,000,000 per accident for bodily injury or disease.
2. **Commercial General Liability Insurance,** including contractual liability insurance, product and completed operations, personal and advertising injury, and any other type of liability for which this Contract applies with limits of liability of not less than \$1,000,000 each occurrence / \$2,000,000 policy aggregate for personal injury, bodily injury, and property damage. Commercial General Liability Insurance shall be written on an "occurrence" form.
3. **Automobile Liability Insurance** with limits of liability of not less than \$1,000,000 per accident for bodily injury and property damage if automobiles are to be used in the delivery of or in the completion of services and work or driven onto the City's property. Insurance shall include all owned, non-owned and hired vehicle liability.
4. **Umbrella Insurance** with limits of liability excess of Employer's Liability Insurance, Commercial General Liability Insurance and Automobile Liability Insurance in the amount of not less than \$3,000,000.
5. **Contractors' Pollution Legal Liability and/or Asbestos Legal Liability and/or Errors and Omissions** (if project involves environmental hazards) with limits not less than \$1,000,000 per occurrence or claim, and \$2,000,000 policy aggregate.
6. **Professional (Errors and Omissions) Insurance-** For Professional Services and for all Design/Build Projects with limits of liability of not less than \$3,000,000 per occurrence or claim / \$3,000,000 policy aggregate. Such policy shall also include coverage for losses arising from the breach of information security or cyber liability (including Errors & Omissions, Security and Privacy Liability and Media Liability), whether combined with the Professional Liability policy or placed as a separate policy, but carrying the same limits of liability. Such coverage shall insure damage, injury and loss caused by error, omission or negligent acts, including all prior acts without limitation, related to the professional services to be provided under this Contract. The policy shall be amended to include independent contractors providing professional services on behalf of or at the direction of the Contractor. The definition of Contractual Liability shall be amended to state that liability under a contract of professional services is covered. Further, coverage shall be afforded for fraudulent acts, misappropriation of trade secrets, internet

professional services, computer attacks, personal injury, regulatory actions, wrongful acts, contractual liability, privacy policy, and insured versus insured. The Contractor shall ensure that coverage under this policy continues for a period of thirty-six (36) months after completion of services.

7. Fidelity Bond (Employee Dishonesty) in the sum of not less than \$50,000.

All such insurance shall remain in effect until final payment is made and the Project is accepted by the City. If the Contractor receives notice of non-renewal or material adverse change of any of the required coverages, the Contractor shall promptly advise the City in writing. Failure of the Contractor to promptly notify the City on non-renewal or material adverse change of any of the required coverages terminates the Agreement as of the date that the Contractor should have given notification to the City. The insurance policies shall contain or be endorsed to contain, the following provisions:

A provision that coverage afforded under such policies shall not expire, be canceled or altered without at least thirty (30) days prior written notice to the City.

Workers' Compensation and Employer's Liability and Property insurance policies shall contain a waiver of subrogation in favor of the City and the City's boards, officials, directors, officers, employees, representatives, agents, and volunteers.

Commercial General Liability, Automobile Liability Contractors' Pollution Legal Liability and/or Asbestos Legal Liability and/or Errors and Omissions (if project involves environmental hazards) insurance policies shall include an endorsement making the City and the City's boards, officials, directors, officers, employees, representatives, agents, and volunteers Additional Insureds under such policies.

A copy of these endorsements shall be provided to the City.

Certificates of Insurance showing that such coverage is in force shall be filed under this Contract by the Contractor to the City.

The obligations for the Contractor to procure and maintain insurance shall not be construed to waive or restrict other obligations and it is understood that insurance in no way limits liability of the Contractor whether or not same is covered by insurance.

Certificate Holder should read: The City of Brookhaven, 4362 Peachtree Road Brookhaven, Georgia 30319.

BONDING REQUIREMENTS

Each bid must be accompanied with a BID BOND (bond only: certified checks or other forms are not acceptable) in an amount equal to five percent (5%) of the base bid, payable to the City of Brookhaven. Said bid bond guarantees the bidder will enter into a contract to construct the project strictly within the terms and conditions stated in this bid and in the bidding and contract documents, should the construction contract be awarded.

The Successful Bidder shall be required to furnish a bond for the faithful performance on the contract and a bond to secure payment of all claims for materials furnished and/or labor performed in performance of the project, both in amounts equal to one hundred percent (100%) of the contract price.

The Successful Bidder shall also be required to furnish a Maintenance Bond, in the amount of one-third (1/3) of the contract price, guaranteeing the repair or replacement caused by defective workmanship or materials for a period of one (1) year from the completion of construction.

Bonds shall be issued by a corporate surety appearing on the Treasury Department's most current list (Circular 570 as amended) and be authorized to do business in the State of Georgia.

Date of Bond must not be prior to date of Contract. If Contractor is a Partnership, all partners shall execute Bond.

BID BOND

KNOW ALL MEN BY THESE PRESENTS, THAT _____

(Name of Contractor) _____

(Address of Contractor) at

(Corporation, Partnership and or Individual) hereinafter called Principal, and

(Name of Surety)

(Address of Surety)

A corporation of the State of _____, and a surety authorized by law to do business in the State of Georgia, hereinafter called Surety, are held and firmly bound unto

City of Brookhaven Georgia

(Name of Obligee)

4362 Peachtree Road Brookhaven, Georgia 30319

(Address of Obligee)

herein after referred to as Obligee, in the penal sum of _____ Dollars (\$ _____) in lawful money of the United States, for the payment of which sum well and truly to be made, we bind ourselves, our heirs, executors, administrators and successors, jointly and severally, firmly by these presents.

WHEREAS, the Principal is about to submit, or has submitted, to the City of Brookhaven, Georgia, a proposal for furnishing materials, labor and equipment for:

TITLE

WHEREAS, the Principal desires to file this Bond in accordance with law in lieu of a certified Bidder's check otherwise required to accompany this Proposal.

NOW, THEREFORE, the conditions of this obligation are such that if the bid is accepted, the Principal shall within ten days after receipt of notification of the acceptance execute a Contract in accordance with the Bid and upon the terms, conditions, and prices set forth in the form and manner required by the City of Brookhaven, Georgia, and execute a sufficient and satisfactory Performance Bond and Payment Bond payable to the City of Brookhaven, Georgia, each in an amount of 100% of the total Contract Price, in form and with security satisfactory to said the City of Brookhaven, Georgia, and otherwise, to be and remain in full force and virtue in law; and the Surety shall, upon failure of the Principal to comply with any or all of the foregoing requirements within the time specified above, immediately pay to the City of Brookhaven, Georgia, upon demand, the amount hereof in good and lawful money of the United States of

America, not as a penalty, but as liquidated damages.

PROVIDED, FURTHER, that Principal and Surety agree and represent that this bond is executed pursuant, to and in accordance with the applicable provisions of the Official Code of Georgia Annotated, as Amended, including, but not limited to, O.C.G.A. SS 13-10-1, et. Seg. And SS 36-86-101, et. Seg. And is intended to be and shall be constructed as a bond in compliance with the requirements thereof.

Signed, sealed, and dated this _____ day of _____ A.D.,
20____

ATTEST:

(Principal Secretary)

(SEAL)

(Witness to Principal)

(Address)

(Surety)

ATTEST

BY: _____
(Attorney-in-Fact) and Resident Agent

(Attorney-in-Fact)

(Seal)

(Address)

(Witness as to Surety)

(Address)

(Principal)

BY: _____

(Address)

PERFORMANCE BOND

KNOW ALL MEN BY THESE PRESENTS: THAT

(Name of Contractor)

(Address of Contractor)

a _____
(Corporation, Partnership or Individual)

Hereinafter called Principal, and

(Name of Surety)

(Address of Surety)

A Corporation of the State of _____ and a surety authorized by law to do business in the State of Georgia, hereinafter called Surety, are held and firmly bound unto

The City of Brookhaven, Georgia
(Name of Obligee)

4362 Peachtree Road NE, Brookhaven, GA. 30319
(Address of Obligee)

hereinafter referred to as Obligee; are held firmly bound unto said Obligee and all persons doing work or furnishing skill, tools, machinery, supplies, or material under or for the purpose of the Contract hereinafter referred to, in the penal sum of:
_____ Dollars (\$ _____) in lawful money of the United States, for the payment of which sum well and truly to be made, we bind ourselves, our heirs, executors, administrators and successors, jointly and severally, firmly by these presents.

The condition of this obligation is such, as whereas the Principal entered into a certain contract, hereto attached, with the Obligee, dated _____ for:

NOW THEREFORE, the conditions of this obligation are such that if the above bound Principal shall well, truly, fully and faithfully perform said contract according to its terms, covenants, conditions, and agreements of said contract during the original term of said contract and any extensions thereof that may be granted by the obligee, with or without notice to the Surety, and during the life of any guaranty required under the contract, and shall also well and truly perform and fulfill all the undertakings, covenants, terms, conditions and agreement of any and all duly authorized modifications of said contract that may hereafter be made, then his obligation shall be void, otherwise to remain in full force and effect.
PROVIDED FURTHER, that said Surety to this Bond, for value received, hereby stipulates and

agrees that no change, extension of time, alterations, or additions to the terms of the Contract or to the Work to be performed there under shall in any way affect its obligation on this bond, and it does hereby waive notice of any such change, extension of time, alterations, or additions to the terms of the Contract or to the work to be performed there under.

PROVIDED FURTHER, that Principal and Surety agree and represent that this bond is executed pursuant to and in accordance with the applicable provisions of the Official Code of Georgia Annotated, as Amended, including but not limited to, O.C.G.A. SS 13-10-1 et. Eq. and SS 36-86-101, et. Seg., and is intended to be and shall be construed as a bond in compliance with the requirements thereof.

Signed, sealed, and dated this _____ day of _____, 2018

ATTEST:

(Principal Secretary)

(Principal)

(SEAL)

BY: _____

(Witness to Principal)

(Address)

(Surety)

ATTEST:

Attorney-in-Fact) and Resident Agent

(Attorney-in-Fact)

(Seal)

(Address)

(Witness as to Surety)

(Address)

PAYMENT BOND

KNOW ALL MEN BY THESE PRESENTS: THAT

(Name of Contractor)

(Address of Contractor)

a _____
(Corporation, Partnership or Individual)

Hereinafter called Principal, and

(Name of Surety)

(Address of Surety)

a Corporation of the State of _____ and a surety authorized by law to do business in the State of Georgia, hereinafter called Surety, are held and firmly bound unto

The City of Brookhaven Georgia
(Name of Obligee)
4362 Peachtree Road NE, Brookhaven, Georgia 30319
(Address of Obligee)

hereinafter referred to as Obligee; for the use and protection of all subcontractors and all persons supplying labor, services, skill, tools, machinery, materials and/or equipment in the prosecution of the work provided for in the contract herein after referred to in the full and just sum of _____ Dollars (\$) in lawful money of the United States, for the payment of which sum well and truly to be made, the Principal and Surety bind themselves, their, and each of their heirs, executors, administrators, successors and assigns, jointly and severally, firmly by these presents.

The condition of this obligation is such, as whereas the Principal entered into a certain contract. hereto attached, with the Obligee, dated _____ for _____.

NOW, THEREFORE, the conditions of this obligation are such that if the Principal shall well, truly, and faithfully perform said Contract in accordance to its terms, covenants, and conditions, and shall promptly pay all persons furnishing labor, materials, services, skill, tools, machinery and/or equipment for use in the performance of said Contract, then this obligation shall be void; otherwise, it shall remain in full force and effect.

All persons who have furnished labor, materials, services, skill, tools, machinery and/or equipment for use in the performance of said Contract shall have a direct right of action on this Bond, provided payment has not been made in full within ninety (90) days after the last day on which labor was performed, materials, services, skill, tools, machinery, and equipment furnished or the subcontract completed.

PROVIDED FURTHER, that said Surety to this Bond, for value received, hereby stipulates and agrees that no change, extension of time, alterations, or additions to the terms of the Contract or to the Work to be performed there under shall in any way affect its obligation on this bond, and it does hereby waive notice of any such change, extension of time, alterations, or additions to the terms of the Contract or to the work to be performed there under.

PROVIDED HOWEVER, that no suit or action shall be commenced hereunder by any person furnishing labor, materials, services, skill, tools, machinery, and/or equipment having a direct contractual relationship with a subcontractor, but no contractual relationship express or implied with the Principal:

Unless such person shall have given notice to the Principal within 120 days after such person did, or performed the last of the work or labor, or furnished the last of the materials, services, skill, tools, machinery and/or equipment for which claim is made, stating with substantial accuracy the amount claimed and the name of the party to whom the materials, services, skill, tools, machinery and/or equipment were furnished, or for whom the work or labor was done or performed. Such a notice shall be served by mailing the same by registered mail, postage prepaid, in an envelope addressed to the Principal, at any place where an office is regularly maintained for the transaction of business, or served in any manner in which legal process may be served in the State in which the aforesaid project is located, save that such service need not be made by a public officer, and a copy of such notice shall be delivered to the Obligee, to the person and at the address provided for in the Contract, within five days of the mailing of the notice to the Principal.

PROVIDED FURTHER, that any suit under this bond must be instituted before the expiration of one year after the acceptance of the public works covered by the Contract by the proper authorities.

PROVIDED FURTHER, that Principal and Surety agree and represent that this bond is executed pursuant to and in accordance with the applicable provisions of the Official Code of Georgia Annotated, as Amended, including, but not limited to, O.C.G.A. SS 13-10-1, et. Eq. and SS 36-86-101, et. Seg., and is intended to be and shall be construed as a bond in compliance with the requirements thereof.

Signed, sealed, and dated this _____ day of _____, 2018

ATTEST:

(Principal Secretary)
(Seal)

(Principal)

BY:

(Witness to Principal)

(Address)

(Address)

(Surety)

ATTEST

BY:

(Attorney-in-Fact) and Resident

Agent

(Attorney-in-Fact)

(Seal)

(Address)

(Witness as to Surety)

(Address)

QUALIFICATIONS SIGNATURE AND CERTIFICATION
(Bidder to sign and return)

I certify that this offer is made without prior understanding, agreement, or connection with any corporation, firm, or person submitting a proposal for the same materials, supplies, equipment, or services and is in all respects fair and without collusion or fraud. I understand collusive bidding is a violation of State and Federal Law and can result in fines, prison sentences, and civil damage awards. I agree to abide by all conditions of the proposal and certify that I am authorized to sign this proposal for the proposer. I further certify that the provisions of the Official Code of Georgia Annotated, Sections 45-10-20 et. Seq. have not been violated and will not be violated in any respect.

Authorized Signature _____ Date _____

Print/Type Name _____

Print/Type Company Name Here _____

CORPORATE CERTIFICATE

I, _____, certify that I am the Secretary of the Corporation named as Contractor in the foregoing bid; that _____ who signed said bid in behalf of the Contractor, was then (title) _____ of said Corporation; that said bid was duly signed for and in behalf of said Corporation by authority of its Board of Directors, and is within the scope of its corporate powers; that said Corporation is organized under the laws of the State of _____.

This _____ day of _____, 20 _____

(Signature) (Seal)

LIST OF SUBCONTRACTORS

I do _____, do not _____, propose to subcontract some of the work on this project. I propose to Subcontract work to the following subcontractors:

Company Name: _____

The City of Brookhaven requires 51% participation by the prime Contractor on all projects.

GEORGIA SECURITY AND IMMIGRATION COMPLIANCE ACT AFFIDAVIT

Service Provider(s) Name: _____

By executing this affidavit, the undersigned person or entity verifies its compliance with O.C.G.A. § 13-10-91, stating affirmatively that the individual, firm, or corporation has registered with, is authorized to participate in, and is participating in the federal work authorization program commonly known as E-Verify* in accordance with the applicable provisions and deadlines.

The undersigned person or entity further agrees that it will continue to use the federal work authorization program throughout the contract period, and it will contract for the physical performance of services in satisfaction of such contract only with subcontractors who present an affidavit to the undersigned with the information required by O.C.G.A. § 13-10-91(b).

The undersigned person or entity further agrees to maintain records of such compliance and provide a copy of each such verification to the City of Brookhaven within five (5) business days after any subcontractor(s) is/are retained to perform such service.

E Verify
TM Company Identification Number Date of Authorization

BY: Authorized Officer or Agent Date
(Name of Person or Entity)

Title of Authorized Officer or Agent

Printed Name of
Authorized Officer or Agent

**SUBSCRIBED AND SWORN
BEFORE ME ON THIS THE**

DAY OF _____,
201_

My Commission Expires: _____

[NOTARY SEAL]

*or any subsequent replacement operated by the United States Department of Home Security or any equivalent federal work authorization program operated by the United States Department of Homeland Security to verify information of newly hired employees, pursuant to the Immigration Reform and Control Act of 1986 (IRCA), P.L. 99-60.

DRUG FREE WORKPLACE

The undersigned certifies that the provisions of Code Sections 50-24-1 through 50-24-6 of the Official Code of Georgia Annotated, relating to the “Drug-free Workplace Act”, have been complied with in full. The undersigned further certifies that:

- (1) A drug-free workplace will be provided for the Contractor’s employees during the performance of the Contract; and
- (2) Each Contractor who hires a Subcontractor to work in a drug-free workplace shall secure from that Subcontractor the following written certification:

“As part of the subcontracting agreement with _____
(Contractor), _____ (Subcontractor) certifies to the Contractor that a drug free workplace will be provided for the Subcontractor’s employees during the performance of this Contract pursuant to paragraph (7) of subsection (b) of Code Section 50-24-03.”

Also, the undersigned further certifies that he will not engage in the unlawful manufacture, sale, distribution, dispensation, possession, or use of a controlled substance or marijuana during the performance of the Contract.

Company Name

BY: Authorized Officer or Agent Date
(Contractor Signature)

Title of Authorized Officer or Agent of Contractor

Printed Name of Authorized Officer or Agent
